

Data Book

TR-W-G05-Z 1A00 - 6D00_201903_EN HFC R513A



TR-W-G05-Z 1A00 - 6D00

High efficiency water cooled chiller



(The photo of the unit is indicative and may vary depending on the model)

- ✓ NO COMPROMISE
- ✓ VERY HIGH EFFICIENCY
- ✓ FLEXIBLE COMPOSITION

- ✓ ADAPTABILITY
- ✓ LOW INRUSH CURRENTS
- ✓ EXTREMELY SILENT OPERATION





Voluntary product certifications



Check ongoing validity of certificate:
www.eurovent-certification.com

or

www.certiflash.com



System certifications



MITSUBISHI ELECTRIC HYDRONICS & IT COOLING SYSTEMS S.p.A.

Quality System complying with the requirements of UNI EN ISO 9001:2008 regulation

Environmental Management System complying with the requirements of UNI EN ISO 14001:2004 regulation

Occupational Health and Safety Management System complying with the requirements of BS OHSAS 18001:2007

INDEX**TR-W-G05-Z 1A00 - 6D00**

1.1	PRODUCT PRESENTATION	pg.1.1.1 / 1.1.1
2.1	INCIPIIT	pg.2.1.1 / 2.1.1
3.1	UNIT STANDARD COMPOSITION	pg.3.1.1 / 3.1.2
4.1	OPTIONS	pg.4.1.1 / 4.1.4
5.1	GENERAL TECHNICAL DATA	pg.5.1.1 / 5.1.7
6.1	TECHNICAL DATA SEASONAL EFFICIENCY IN COOLING (EN14825 VALUE)	pg.6.1.1 / 6.1.0
7.1	OPERATING LIMITS	pg.7.1.1 / 7.1.4
8.1	HYDRAULIC DATA	pg.8.1.1 / 8.1.2
9.1	ELECTRICAL DATA	pg.9.1.1 / 9.1.2
10.1	FULL LOAD SOUND LEVEL	pg.10.1.1 / 10.1.3
11.1	DIMENSIONAL DRAWINGS	pg.11.1.1 / 11.1.4

Liability disclaimer

The present publication is drawn up by of information only and does not constitute an offer binding upon Mitsubishi Electric Hydronics & IT Cooling Systems S.p.A.

Mitsubishi Electric Hydronics & IT Cooling Systems S.p.A. has compiled the content of this publication to the best of its knowledge. The data contained herein are subject to change without notice. Mitsubishi Electric Hydronics & IT Cooling Systems S.p.A. explicitly rejects any liability for any direct or indirect damage, in the broadest sense, arising from or related to the use and/or interpretation of this publication. All content is copyrighted by Mitsubishi Electric Hydronics & IT Cooling Systems S.p.A.

The units highlighted in this publication contain R513A [GWP₁₀₀ 631] fluorinated greenhouse gases.



LEGEND

TR-W-G05-Z 1A00 - 6D00

Functions



Cooling

Refrigerant



R513A

Compressors



Centrifugal compressor

Exchangers



Flooded evaporator

Other features right position



Energy Class A

Other features



Eurovent



VPF



VSpeed



GREEN Certification relevant

1.1 PRODUCT PRESENTATION

Indoor unit for the production of chilled water featuring centrifugal compressors oil-free, with R513A, electronic regulation valve, shell and tube condenser and shell and tube flooded evaporator.

Base and supporting structure and panels are of galvanized epoxy powder coated steel with increased thickness.

Flexible and reliable unit; it easily adapts itself to different thermal load conditions thanks to the precise thermoregulation together with the use of inverter technology. The compressor is radically innovative: magnetic bearings and digital rotor speed control allow partial load efficiency levels to be reached that were hither to impossible.

1.3 NO COMPROMISE

Large availability in the combinations of the compressors (up to 6 compressors on the same unit), plus the flexibility in the choice of the heat exchangers can satisfy each specific installation and design requirements: the highest full load efficiency, the best initial investment, an unrivaled seasonal efficiency, an operating range suitable for applications in systems operating at high or low condensation (dry coolers or cooling towers)

1.4 VERY HIGH EFFICIENCY

Very high efficiency at full and partial load, to top market levels, thanks to adopted technological solutions: large capacity modulation and expanded exchanger, offering minimum running costs of the unit in real working conditions.

1.5 FLEXIBLE COMPOSITION

Choice between horizontal or diagonal arrangement of the heat exchangers, with dimensions that favor the compact overall dimensions in height or plant, water connections to the evaporator and condenser that can be deployed on the right or left, to fit for all applications

1.6 ADAPTABILITY

Adaptability at the building's heating request thanks to the continuous capacity regulation, assured by sophisticated control's logic.

1.7 LOW INRUSH CURRENTS

Reduced breakaway starting currents thanks to the revolutionary centrifugal compressor.

1.8 EXTREMELY SILENT OPERATION

Extremely silent operation in line with the best on the market, and highly reduced vibrations

TR-W-G05-Z / 6D00

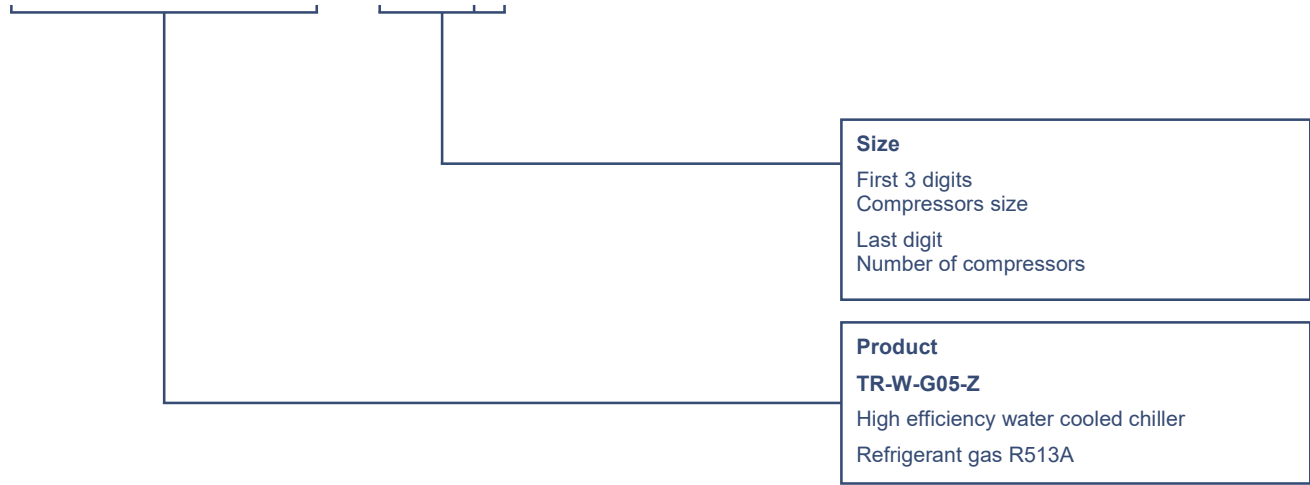

3.1 UNIT STANDARD COMPOSITION

3.2 High efficiency water cooled chiller

Indoor unit for the production of chilled water featuring centrifugal compressors oil-free, with R513A, electronic regulation valve, shell and tube condenser and shell and tube flooded evaporator.

Base and supporting structure and panels are of galvanized epoxy powder coated steel with increased thickness.

Flexible and reliable unit; it easily adapts itself to different thermal load conditions thanks to the precise thermoregulation together with the use of inverter technology. The compressor is radically innovative: magnetic bearings and digital rotor speed control allow partial load efficiency levels to be reached that were hither to impossible.

3.3 Structure

Frame in polyester-painted galvanized steel.

The self-supporting frame is built to guarantee maximum accessibility for servicing and maintenance operations.

- Electrical panel positioned on the long side of the unit. Choice of horizontal or diagonal layout of the heat exchangers, with dimensions that favour the compact overall dimensions in width (diagonal layout, standard in 1-2-3-4 compressors units) or height (horizontal layout, standard in 5-6 compressors units and optional in 3-4 compressors units). The evaporator and the condenser water connections are located to the right of electrical panel, but can be deployed either on the left or right side to fit for all applications.
- Lau-y-out with lifting eyes and handling slides (in units with 3-4-5-6 compressors).

3.4 Refrigerant circuit

Unit designed with a single refrigerant circuit in order to optimize the heat exchange's process, especially in part load mode, without any risk in the proper management of oil which is, in this series, completely absent. Standard components of the refrigerant circuits are, in addition to the previous one:

- electronic expansion valve
- dedicated sensor level on condenser side
- high and low pressure safety valve with visualization of the pressure's level and the rotational speed directly from the controller's interface
- on-off cock on the compressor's suction and delivery line and on the refrigerant line
- safety switching device for limiting the pressure
- drier filter with replaceable cartridge
- refrigerant line sight glass with humidity indicator
- check valve on compressor gas discharge line
- economizer circuit (one for each compressor)
- valve on economizer port on the compressor
- by-pass valve on discharge line for compressor staging

3.5 Compressor refrigerant circuit

Refrigerant circuit is designed for the minimum pressure drops. At the suction of each compressor is mounted a curve, designed with the help of sophisticated computational techniques CFD and FEM, dramatically reducing the size, the length of suction pipes to the compressors and the related pressure drops.



3.6 Compressor

Two stage, variable speed, centrifugal compressor with aluminium impellers, designed requiring no oil for lubrication. Compressor constructed with cast aluminium casing and high-strength thermoplastic electronics enclosures. Compressor provided with radial and axial magnetic bearings to levitate the shaft thereby eliminating metal to metal contact, and thus eliminating friction and the need for oil. Each bearing position is sensed by position sensors to provide real-time repositioning of the rotor shaft, controlled by the on-board digital electronics. Compressor speed is reduced as condensing temperature and/or heat load reduces, optimizing energy performance through the entire range.

Continuous modulation is possible thanks to the integrated inverter. Signals from the compressor controller determine the inverter output frequency, voltage and phase, thereby regulating the motor speed. In case of power failure, the compressor is capable of allowing for a normal de-levitation and shutdown. Inlet Guide Vanes is built-in to further trim the

compressor capacity in conjunction with the variable-speed control, to optimize compressor performance at low loads.

The compressor is provided with a direct drive, high efficiency, permanent-magnet synchronous motor powered by pulse-width-modulating (PWM) voltage supply. Motor cooling is by liquid refrigerant injection, directly managed by the compressor. A non-return valve on the discharge port of the compressor is installed to protect against backflow of refrigerant during coastdown; a thermal protection protects against over-currents while a soft-charge device reduces in-rush starting current under 2 amps.



- TX-W units have been designed for hosting from 1 to 6 compressors. In multi-compressor units, it is possible having different models (sizes) of compressors on the same circuit.

3.7 Plant side heat exchanger

Shell and tube heat exchanger, fully designed and manufactured by MEHITS, working as flooded type evaporator, with water flowing inside the pipes and refrigerant flowing in the shell side. The steel shell is insulated with a foamed polyethylene closed-cell mat of 9 mm thickness and a thermal conductivity of 0,033 W/mK at 0°C. The copper pipes are internally and externally grooved in order to improve the heat exchange. Integrated system to avoid liquid entrainment and to protect the compressor against the risk of liquid suction. A differential pressure switch is fitted in order to control the water flow while the unit is working, avoiding the risk of ice generation. An electric heater, operating when antifreezing mode is active, is present on the shell. The pipes' flooding is controlled by an electronic expansion valve, managed by proprietary logics to guarantee the proper refrigerant flow and the complete flooding of pipes in all conditions of compressors' load. The heat exchanger complies with PED standards, concerning the operating pressures.

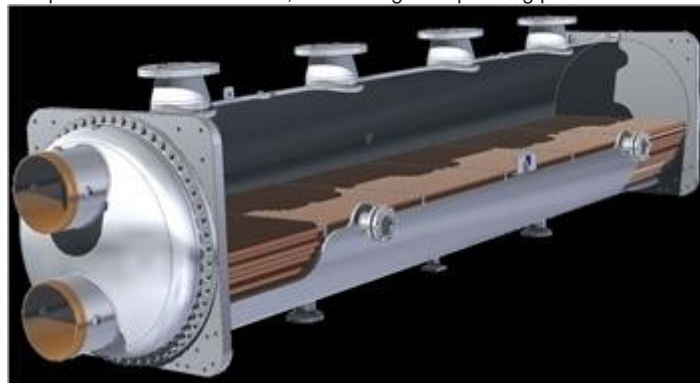

- To reduce water side pressure drops and related pumping costs, the evaporator is optimized for a delta T= 5K in all the sizes up to 1500 kW, while in bigger sizes the optimized delta T is 6K. PS water side = 10 bar, PS refrigerant side = 16 bar.
- Evaporator with two passages water circuit, with inlet and outlet water connections on the same side. Grooved coupling with weld end counter-pipe user side

3.8 Source side heat exchanger

Heat exchanger, with a function of condenser, shell and tubes, flooded type, with water flowing inside and refrigerant flowing outside the pipes. The copper tubes are internally and externally grooved to improve heat exchange and minimize the approach between water and condensing

UNIT STANDARD COMPOSITION

refrigerant (the result is a better efficiency in compressors operation). Heads can be removed to inspect the tubes. Exchanger with two passages water side, with inlet and outlet water connections on the same side. Grooved coupling with weld end counter-pipe user side. Design optimized for minimum pressure drops water side (optimum $\Delta T = 5K$) and refrigerant side (in some sizes, condenser can have inclined refrigerant connections, to limit the length of refrigerant discharge pipes). The heat exchanger complies with PED standards, concerning to operating pressure (PS =20 bar refrigerant side, PS= 10 bar water side).

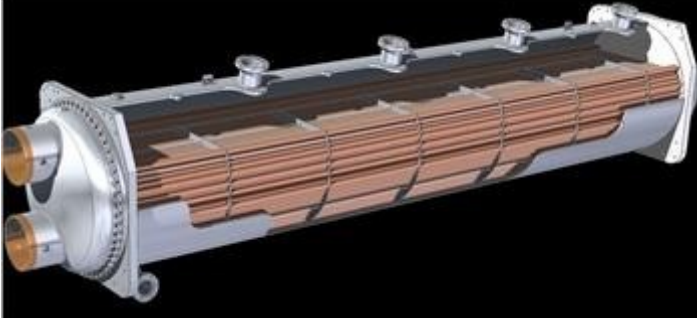

3.9 Electrical and control panel

Electrical and control panel built to EN60204-1 and EC204-1 standards, complete with:

- electronic controller
- control circuit transformer
- general door lock isolator
- power circuit with electric bus bar distribution system
- EMC filter and reactor on the compressor's power circuit
- fuses for the compressors
- spring-type control circuit terminal board
- relays for remote pump(s) activation for plant side and heat source side (only for units without hydronic pumps)
- digital input on / off unit from remote
- digital output signal general alarm
- on / off unit from user interface
- 0-10V analog output for external condensation control (maximum 30 m)
- digital output compressor on
- modbus interface for communication between controller and compressors
- aeration of electrical panel

3.10 Certification and applicable directives

The unit complies with the following directives and relative amendments:

- EUROVENT Certification program
- CE Declaration of conformity certificate for the European Union
- EAC Product quality certificate for Russian Federation
- SAFETY QUALITY LICENCE Product quality certificate for Popular Republic of China
- M&I Product quality certificate for Australia and New Zealand
- PED Directive 2014/68/EC
- Machinery Directive 2006/42/EC
- Low Voltage directive 2006/95/EC
- ElectroMagnetic compatibility directive 2004/108/EC
- ErP Directive 2009/125/EC
- F-Gas Regulation 517/2014/EC
- 811/2013/EC and 813/2103/EC EcoLabelling Regulations
- ISO 9001 Company's Quality Management System certification
- ISO 14001 Company's Environmental Management System certification

3.11 Tests

Tests performed throughout the production process, as indicated in ISO9001.

Performance or noise tests can be performed by highly qualified staff in the presence of customers.

Performance tests comprise the measurement of:

- electrical data
- water flow rates
- working temperatures
- power input
- power output
- pressure drops on the water-side exchanger both at full load (at the conditions of selection and at the most critical conditions for the condenser) and at part load conditions.

During performance testing it is also possible to simulate the main alarm states.

Noise tests are performed to check noise emissions according to

ISO9614.

3.12 CX4 electronic controller

The brandnew CX4 controller offers advanced functions and algorithms. When units are supplied with digital interface on the machine, it comes with a large touchscreen display 13 "colour.

The screens are developed with graphics created exclusively for the family TX-W. The home page allows the immediate visualization of the status of the unit and its main operating parameters, while more specific screens allow a closer view of all the variables related to the compressors, the heat exchangers and the refrigerant circuit. It is possible the analysis in graphical form of the monitored and measured variables. Secure access to data is guaranteed by three different password levels (user, service, manufacturer).

The controller allows easy assessment and operation on the unit by a multi-level menu, with selectable user's language.

The temperature control is characterized by the continuous capacity modulation, based on PID algorithms and related to the leaving water temperature, with adjustment on the neutral areas.

The diagnostics includes a complete alarm management, with the "black box" (via PC) and registration of alarms (via display or PC) for a better analysis of the unit performance.

Supervision is achievable through various options, with proprietary devices or with the integration in third party systems by means of the most common communication protocols (ModBus, BACnet-over-IP, Echelon LonWorks, BACnet MS / TP..., Konnex). Connection with remote touchscreen is available.

The presence of programmable timer allows the creation of an operating profile containing up to 7 days and 6 type bands, with automatic transmission from summer time to winter time.

For systems consisting of multiple units, the management of the resources is possible via optional proprietary devices.

Optionally (VPF package), capacity modulation can be integrated with hydraulic flow modulation, thanks to inverter-driven pumps and to specific resources for the hydraulic circuit.



4.1 OPTIONS

OPTIONS	DESCRIPTIONS	BENEFITS	AVAILABLE FOR MODELS
1960 PRESSURE RELIEF VALVES			
1961 DUAL RELIEF VALVES WITH SWITCH	Dual relief valve with switch	Allows to unselect a relief valve in order to service the unit avoiding medium or long inoperative periods	ALL
380 NUMBERED WIRING			
381 NUMBERED WIRING ON EL. BOARD	Electrical board wires are identified by numbered labels. The reference numbers are indicated in the unit's wiring scheme.	Facilitate maintenance interventions to the electrical board connections.	ALL
3300 COMPRESSOR REPHASING			
3302 COMPR.POWER FACTOR CORR.0,95	Capacitors on the compressors' power inlet line.	The unit's average cos(phi) increases.	ALL
4180 REMOTE CONNECTION ARRANGEMENT			
4181 SERIAL CARD MODBUS	Interface module for ModBUS protocols.	Allows integration with BMS operating with ModBUS protocol.	ALL
4182 SERIAL CARD FOR LONWORKS	Interface module for Echelon systems.	Allows integration with BMS operating with LonWorks protocols	ALL
4184 SERIAL CARD BACNET MS/TP RS485	Interface module for BACnet protocols.	Allows integration with BMS operating with BACnet protocol.	ALL
4185 SERIAL CARD FOR BACNET OVER IP	Interface module for BACnet OVER-IP protocols.	Allows to interconnect BACnet devices over Internet Protocol within wide-area networks.	ALL
4187 M-Net W3000 INTERFACE KIT	Interface kit for M-Net protocol.	Interface module to allow the integration of the unit with Mitsubishi Electric proprietary communication protocol M-Net.	ALL
6160 AUXILIARY INPUT			
6161 AUXILIARY SIGNAL 4-20mA	4-20 mA analog input	Allows to change the operating set-point according to the value of current applied to the analogue input.	ALL
6162 REMOTE SIGNAL DOUBLE SP	Allows to activate the Energy Saving set-point.	Allows to change the operating set-point according to a remote switch	ALL
6170 DEMAND LIMIT			
6171 INPUT REMOTE DEMAND LIMIT	Digital input (voltage free)	It permits to limit the unit's power absorption for safety reasons or in temporary situation.	ALL
1440 USER INTERFACE			
1443			ALL
6196 KIPlink	The unit is equipped with KIPlink, the innovative user interface based on WiFi technology		ALL
6197 13 INCH TOUCH SCREEN	64 K colour 13,3"(diagonal) display keyboard, resolution 1280X800 WVGA, with adjustable led backlight (WARNING: with ambient temperature below 0°C the display response time may visibly increase)	The touch-screen's technology is characterized by an easy-to-access data, and it allows an effective graphical representation of the main figures protecting the access through 3 privilege levels.	ALL

OPTIONS

OPTIONS	DESCRIPTIONS	BENEFITS	AVAILABLE FOR MODELS
3350 WATER FLOW REGULATION :			
3351 WITH VPF SYSTEM (SIG. 0-10V)	Pre-arrangement for the control of the inverter driven pumps for the plant's primary circuit (see dedicated section). This option includes: differential pressure transducer on the evaporator, additional control devices to read the signals (4-20 mA) coming from the differential pressure transducers on the evaporator and on the plant and to manage the pumps and the by-pass valve (0-10V signals). [Plant differential pressure transducers, pumps and by-pass valve to be supplied by others].	Energy consumption associated with fluid circulation drops significantly, very often over 50%. Beyond the energy saving and the consequent lower operating costs, this new approach enables simplification in the plant's design that ensures substantial savings in initial investment costs. The integration of variable flow pumps on board, permits significant savings in overall dimensions, circuit components and in the system's commissioning.	ALL
3352 WITH VPF.D SYSTEM (SIG. 0-10V)	Pre-arrangement for the control of the inverter driven pumps for the plant's primary circuit in installation with hydraulic decoupler (see dedicated section). This option includes: temperature sensors to be installed on the plant, additional control devices to read the signals (4-20 mA) coming from the plant temperature sensors and to manage the pump speed (0-10V signal). [Pumps to be supplied by others].	Energy consumption associated with fluid circulation drops significantly, very often over 50%. Beyond the energy saving and the consequent lower operating costs, this new approach enables simplification in the plant's design that ensures substantial savings in initial investment costs. The integration of variable flow pumps on board, permits significant savings in overall dimensions, circuit components and in the system's commissioning.	ALL
3430 REFRIGERANT LEAK DETECTOR			
3431 REFRIG. LEAK DETECTOR	Refrigerant leak detection system, supplied factory mounted and wired in the electrical board. In case of leak detection it will raise an alarm.	It promptly detects gas leakages	ALL
3432 REFRIG. LEAK DETECTOR+MIGR.	Refrigerant leak detection and migration system. In case the device detects a leakage the unit stops and stores the remaining refrigerant inside the evaporator, waiting for the intervention of a technician.	It promptly detects gas leakages, stops the unit and stores the remaining refrigerant.	ALL
3433 GAS LEAK CONTACT + COMPR. OFF	Refrigerant leak detection system, supplied factory mounted and wired in the electrical board. In case of leak detection it will raise an alarm and stop the unit.	It promptly detects gas leakages and stops the unit	ALL
3450 ELECTR. COMP. AS IEC 61000-6			
3451 EMC COMP. FOR RESIDENTIAL APP.	EMC compatibility for residential applications as per EN61000-6-3	Assure units' EMC compatibility as per EN61000-6-3, for residential, commercial and light industrial applications.	ALL
5920 MANAGEMENT & CONTROL SYSTEMS			
5924 ENERGY METER FOR BMS	This option includes all following devices on-board the unit panel: - network analyzer with display operating on ModBUS protocol over RS-485 (without certification MID) - current transformers.	This accessory allows to acquire the electrical data and the power absorbed by the unit and send them via RS-485 bus to the BMS for energy metering.	ALL
4500 FAST RESTART (UPS EXCLUDED)			
4501 FAST RESTART (UPS EXCLUDED)	Unit fast restart management after power failure	The management of the fast restart allows to minimize downtimes in case of power failure, keeping all the necessary unit safeties. This option requires an external 203V AC 300VA UPS power supply, by customer.	ALL
1280 CONDENSER CONFIGURATION			
1281 2 PASS CONDENSER	Inlet and outlet water connections on the same head	Inlet and outlet water connections on the same head	ALL

OPTIONS

OPTIONS	DESCRIPTIONS	BENEFITS	AVAILABLE FOR MODELS
1800 EVAPORATOR WATER FLOW SWITCH			
1801 EVAPORATOR WATER FLOW SWITCH	Flow switch with stainless scoop AISI 316L and IP65 protection suitable for installation in industrial plant pipes. It should be installed in a straight pipe without filters, valves, etc., long at least 5 times its diameter, both upstream and downstream.	Signaling of lack of or excessive reduction of flow, it generates an alarm that is in automatic or manual reset depending on n ° alarms per hour and the maximum time of operation of the pump under conditions of low flow rate.	ALL
1802 EVAP.DIFFERENTIAL PRESS.SWITCH	Differential pressure switch in silicone membrane, compatible for water and glycolated solutions, suitable to the horizontal and vertical mounting, with an operating range between -20 ° C and + 85 ° C.		ALL
2400 EXCHANGERS ANTIFREEZE HEATER			
2401 EXCHANGERS ANTIFREEZE HEATER			ALL
2630 INSULATION ON EXCHANGERS			
2631 DOUBLE INSULATION ON EXCHANGERS	Thermal insulation in closed-cell flexible elastomeric foam (FEF) of 16 mm coupled with a 3 mm layer of reticulated foam in PE and an exterior embossed finishing PE film. This option is mandatory if the unit is supposed to work with outdoor temperature below -10°C.	Reduces heat losses and prevent from condensate problems.	ALL
2900 WATER CONNECTIONS			
2903 EVAP.FLANGES + COUNTERFLANGES			ALL
2680 WATER CONNECTIONS ORIENTATION			
2682 EVAP. LEFT - COND. RIGHT CONN.	Looking at the unit from the electrical panel side, evaporator water connections are on the left side while condenser water connections are on the right side of the unit,	Adaptability of the water layout to different system configurations.	ALL
2683 EVAP. RIGHT - COND. LEFT CONN.	Looking at the unit from the electrical panel side, evaporator water connections are on right side while condenser water connections are on the left side of the unit.	Adaptability of the water layout to different system configurations.	ALL
2681 EVAP. RIGHT - COND. RIGHT CONN.	Looking at the unit from the electrical panel side, evaporator and condenser water connections are on the right side of the unit,	Adaptability of the water layout to different system configurations.	ALL
2684 EVAP. LEFT - COND. LEFT.CONN.	Looking at the unit from the electrical panel side, evaporator and condenser water connections are on the left side of the unit.	Adaptability of the water layout to different system configurations.	ALL
2690 UNIT CONFIGURATION			
2691 DIAGONAL CONFIGURATION	Evaporator and condenser are arranged with the heads (square) aligned along the same diagonal	Reduced overall footprint and width dimensions to suit different installation requirements.	ALL
2692 HORIZONTAL CONFIGURATION	Evaporator and condenser are arranged with the heads aligned and side by side.	Reduced height dimensions to suit different installation requirements.	ALL
2980 CONDENSER WATER CONN.			
2981 FLANGES CONDENSER CONNECTION			ALL

OPTIONS

OPTIONS	DESCRIPTIONS	BENEFITS	AVAILABLE FOR MODELS
2340 UNIT ENCLOSURE			
2313 INTEGRAL ACOUST.ENCL.STANDARD	Enclosure made from hot galvanised metal plate and painted with epoxy powder coat. The acoustic insulation availability depends on unit model, see the dedicated description in "Accessories notes".	The enclosure allows to reduce the sound level of the unit, see the dedicated description in "Accessories Notes".	ALL
2314 INTEGRAL ACOUST.ENCL.PLUS	Enclosure made from hot galvanised metal plate and painted with epoxy powder coat with a special acoustic insulation, see the dedicated description in "Accessories notes".	The enclosure allows to reduce the sound level of the unit, see the dedicated description in "Accessories Notes".	ALL
2317 PANELING EXCHANGERS SIDE	Covering panels arranged laterally along the exchangers and covering the refrigerant circuit	Refrigerant circuit protection and superior aesthetic finishing.	ALL
2100 ANTIVIBRATION MOUNTING			
2101 RUBBER TYPE ANTIVIBR.MOUNTING			ALL
9970 PACKING			
9979 CONTAINER PACKING	Unit provided with container slides and covered with nylon		ALL
1240 CONDENSING PRESSURE CTRL DEV			
1246 WITH MODULATING SIGNAL 0-10V	0-10 V signal on terminal board for the condensation control.	The 0-10V signal, it allows to manage several condensing devices in order to maintain the condensing pressure in a pre-defined range in every applications: - for well water application to manage a 2 way modulating valve; - for cooling tower application to manage a 3 way modulation valve; - for dry-cooler or cooling tower application to modulate the fans' speed; - for geothermal probe to modulate the pumps' speed.	ALL

ACCESSORIES

Additional information - IMPORTANT -

6197 – Interface touch 13 inch

The touch panel is provided as an accessory since the standard configuration of the unit is with KIPLink without interface.

3431 – Refrigerant leak detector

3432 – Refrigerant leak detector + migration

3433 – Refrigerant leak detector + compressors off

For the proper functioning we recommend to install the unit in closed spaces.

4501 – Fast restart

The “fast restart” function is activated after a power failure when the voltage returns, if the thermoregulator demand is greater than or equal to 100%, or if the outlet temperature is above the upper neutral zone (in the case of neutral zone regulation) or is out of the regulation band (in the case of steps regulation). When the power returns and the temperature is within the neutral zone or within the control band, the “fast restart” function is not activated and the machine starts normally.

Tables 1 e 2 show time frames, defined from the power restoration.

Table 1 – First compressor start-up time		
Standard unit	Unit with fast restart	
	After power outage < 40”	After power outage ≥ 40”
~ 240 “ (**)	< 26 “	50 “

Table 2 – Ramp-up time for 100% cooling capacity		
Standard unit	Unità con fast restart	
	After power outage < 40”	After power outage ≥ 40”
~ 1000 “ (**)	200+80*n	240+120*(n-1) “

Reference conditions: 12-7°C e 30-35°C

n= compressors number

(**): standard boot with flexible steps regulation on the inlet temperature and PID regulation on the outlet

The time frames in table 2 depend on:

- compressors number
- power outage duration
- cooling capacity required
- evaporator and condenser water temperature
- compressors’ operating conditions before the power failure
- maximum number of starts per hour

For the above-mentioned elements, the data listed in table 2 are subject to a tolerance.

1246 – With modulating signal 0-10V for the condensing control

It is supplied as standard.

1801 – Evaporator water flow switch

The accessory is supplied loose.

1802 – Evaporator differential pressure switch

It is supplied as standard.

2631 – Double insulation on evaporator

19 mm thickness of the insulation.

2903 – Flanged evaporator connections

2981 – Flanged condenser connections

PN16, as in the picture, could entail a unit length increase.



2313 – Integral acoustical enclosure “base”

Power noise reduction of 14 dB(A).

C926108911 - KIT remote touch screen 7” (units with W3000 TE controller)

For remote touch screen user interface, the following electrical components are to be supplied by the customer:

- 24Vac or 24Vdc power supply for I_{max}=1A
- Serial cable 3x1 mm² shielded and twisted, max length 500m total.

C926108913 - KIT remote touch screen 13” (units with W3000 TE controller)

For remote touch screen user interface, the following electrical components are to be supplied by the customer:

- 24Vdc power supply for I_{max}=2A
- Serial cable 3x1 mm² shielded and twisted, max length 500m total.

C926108912 - KIT remote touch screen 13” (units with CX4 controller)

For remote touch screen user interface, the following electrical components are to be supplied by the customer:

- 24Vdc power supply for I_{max}=2A
- Ethernet cat 5e cable or higher, max length 100m total. Max length can be increased up to 200m total, using a network switch or hub.

C926108911 - KIT remote touch screen 7”, C926108912 - KIT remote touch screen 13”, C926108913 - KIT remote touch screen 13”

In case of a multiple unit installation, maximum up to 8 units (of which maximum 6 units can be provided with +2P module) may be connected to one single remote touch screen keyboard only if the aforementioned units are provided with the same controller type (W3000 TE or CX4) and the same software version. For further information about multiple connections please refer to the Technical Manual of touch controller.

ACCESSORIES

Chiller Plant Control with Active Optimization System

ClimaPRO System Manager

ClimaPRO System Manager represents the state-of-the-art platform for chiller plant management and control.

ClimaPRO ensures to actively optimize the entire chiller plant by managing and adjusting each component directly involved in the production and the distribution of the heating and the cooling energies, therefore involving chillers and heat pumps, pumping groups as well as the source-side devices like, for example, the cooling towers.

In particular, ClimaPRO measures in real-time all the operating variables from the field, for each individual device and each of the main system branches, by using serial communication lines as well as dedicated analogue signals.

The acquired data are then compared with the design data of each single unit at any different working conditions, thus allowing to implement control strategies based on dynamic algorithms which take into account the real operating conditions.

On the basis of these values, an advanced diagnostic module also allows to assess the level of efficiency for each individual unit, translating data into easy-to-read information in order to simplify and optimize the maintenance activities.

The "Chart Builder" software module allows to display the trends of the main operating variables. The "Reporting" module allows to send reports to selected users, including data and system's status of the main devices as well as to perform calculation of the energy indexes for each single unit and for the entire chiller plant.

The accessibility to ClimaPRO System Manager is ensured by an integrated web server that makes it visible from any computer equipped with a web browser, either locally or remotely.



5.1 GENERAL TECHNICAL DATA

TR-W-G05-Z

[SI System]

TR-W-G05-Z		1A00	1B00	1B1A	1B2A	1B3A	1C00	1C1A	1C1B	1C3B	1D00	
Power supply		V/ph/Hz 400/3/50 400/3/50 400/3/50 400/3/50 400/3/50 400/3/50 400/3/50 400/3/50 400/3/50 400/3/50										
PERFORMANCE												
COOLING ONLY (GROSS VALUE)												
Cooling capacity	(1)(8)	kW	353,0	490,9	844,2	1189	1547	565,9	917,7	1051	2036	734,7
Total power input	(1)(8)	kW	68,71	89,78	158,9	232,7	293,0	99,07	167,4	189,2	365,1	122,0
EER	(1)(8)	kW/kW	5,138	5,467	5,313	5,110	5,280	5,710	5,482	5,555	5,577	6,022
ESEER CALCULATED	(1)(8)	kW/kW	9,520	9,400	9,750	9,450	9,670	9,830	9,840	9,780	9,770	9,470
COOLING ONLY (EN14511 VALUE)												
Cooling capacity	(1)(2)(8)	kW	351,8	489,3	840,9	1185	1541	564,2	914,3	1047	2027	732,1
EER	(1)(2)(8)	kW/kW	4,940	5,250	5,080	4,930	5,050	5,500	5,250	5,320	5,310	5,740
ESEER EN14511 CALCULATED	(1)(2)(8)	kW/kW	8,000	8,040	8,050	8,010	7,950	8,410	8,190	8,190	8,010	7,960
EXCHANGERS												
HEAT EXCHANGER USER SIDE IN REFRIGERATION												
Water flow	(1)(8)	l/s	16,88	23,47	40,37	56,88	74,00	27,06	43,89	50,24	97,36	35,13
Pressure drop	(1)(8)	kPa	39,4	39,4	53,9	44,4	62,5	36,5	52,2	52,0	73,7	48,0
HEAT EXCHANGER SOURCE SIDE IN REFRIGERATION												
Water flow	(1)(8)	l/s	20,09	27,68	47,80	67,75	87,70	31,71	51,73	59,10	114,5	40,86
Pressure drop	(1)(8)	kPa	38,4	38,4	45,3	42,8	49,8	36,5	43,0	42,1	49,2	47,6
CERTIFIED DATA IN EUROVENT												
Cooling capacity	(1)(2)(9)	kW	243,7	364,4	581,9	818,9	1143	458,9	642,5	737,1	1708	658,5
Total power input	(1)(2)(9)	kW	40,80	60,20	96,00	138,6	191,5	75,50	105,2	120,4	289,0	111,8
EER	(1)(2)(9)	kW/kW	5,970	6,050	6,060	5,910	5,970	6,080	6,110	6,120	5,910	5,890
ESEER	(1)(2)(9)	kW/kW	8,760	8,460	8,850	8,670	8,590	8,770	8,810	8,770	8,370	8,060
Cooling energy class			A	A	A	A	A	A	A	A	A	A
HEAT EXCHANGER USER SIDE IN REFRIGERATION												
Pressure drop	(1)(2)(9)	kPa	18,8	21,8	25,7	21,1	34,3	24,1	25,7	25,7	52,2	38,8
HEAT EXCHANGER SOURCE SIDE IN REFRIGERATION												
Pressure drop	(1)(2)(9)	kPa	17,5	20,5	20,7	19,4	26,2	23,5	20,4	20,1	33,9	38,3
REFRIGERANT CIRCUIT												
Compressors nr.		N°	1	1	2	3	4	1	2	2	4	1
No. Circuits		N°	1	1	1	1	1	1	1	1	1	1
Regulation			STEPLESS STEPLESS STEPLESS STEPLESS STEPLESS STEPLESS STEPLESS STEPLESS STEPLESS STEPLESS									
Min. capacity step		%	33,9	34,0	13,9	9,9	7,5	33,4	12,6	15,9	8,1	45,2
Refrigerant			R513A R513A R513A R513A R513A R513A R513A R513A R513A R513A R513A									
Refrigerant charge	(11)	kg	215	220	390	495	747	262	436	416	1078	253
Oil charge		kg	0,00	0,00	0,00	0,00	0,00	0,00	0,00	0,00	0,00	0,00
Rc (ASHRAE)	(3)(8)(11)	kg/kW	0,62	0,45	0,47	0,42	0,49	0,47	0,48	0,40	0,54	0,35
NOISE LEVEL												
Sound Pressure	(4)	dB(A)	75	76	76	78	78	77	77	77	79	78
Sound power level in cooling	(5)(6)	dB(A)	93	94	95	97	98	95	96	96	99	96
SIZE AND WEIGHT												
A	(7)(10)	mm	2910	2910	3050	3710	4690	2910	3050	3050	4720	2910
B	(7)(10)	mm	1000	1000	1620	1710	1890	1000	1620	1620	1890	1000
H	(7)(10)	mm	1950	1950	2190	2260	2400	1950	2190	2190	2400	1950
Operating weight	(7)(10)	kg	2690	2800	5200	7590	9320	2880	5280	5410	11010	2950

Notes:

- 1 Plant (side) cooling exchanger water (in/out) 12,00°C/7,00°C; Source (side) heat exchanger water (in/out) 30,00°C/35,00°C.
- 2 Values in compliance with EN14511
- 3 Rated in accordance with AHRI Standard 550/590 (2011 with addendum 1).
- 4 Average sound pressure level at 1m distance, unit in a free field on a reflective surface; non-binding value calculated from the sound power level.
- 5 Sound power on the basis of measurements made in compliance with ISO 9614.
- 6 Sound power level in cooling, indoors.
- 7 Unit in standard configuration/execution, without optional accessories.
- 8 Values related to the maximum compressors' rotating speed.
- 9 Values refer to the nominal rotational speed of the compressors.
- 10 Values related to standard layout : diagonal in sizes up to 4 compressors, horizontal in sizes with 5 or 6 compressors
- 11 Nominal value, please refer always to the printed value on the unit data plate.

- Not available

Certified data in EUROVENT

GENERAL TECHNICAL DATA

TR-W-G05-Z

[SI System]

TR-W-G05-Z		1D1A	1D1B	1D1C	1D2C	1D3C	1D4C	1D5C	2A00	2B00	2B1A	
Power supply		V/ph/Hz 400/3/50 400/3/50 400/3/50 400/3/50 400/3/50 400/3/50 400/3/50 400/3/50 400/3/50 400/3/50										
PERFORMANCE												
COOLING ONLY (GROSS VALUE)												
Cooling capacity	(1)(8)	kW	1084	1226	1303	1880	2455	3051	3648	708,5	980,2	1329
Total power input	(1)(8)	kW	189,7	211,9	222,4	323,1	423,2	517,3	613,7	137,6	182,1	257,3
EER	(1)(8)	kW/kW	5,714	5,786	5,859	5,819	5,801	5,898	5,944	5,149	5,383	5,165
ESEER CALCULATED	(1)(8)	kW/kW	9,760	9,870	10,00	10,00	9,940	10,20	10,30	9,660	9,750	9,370
COOLING ONLY (EN14511 VALUE)												
Cooling capacity	(1)(2)(8)	kW	1080	1221	1298	1872	2443	3035	3631	706,1	976,5	1325
EER	(1)(2)(8)	kW/kW	5,440	5,500	5,580	5,530	5,510	5,560	5,610	4,940	5,160	4,990
ESEER EN14511 CALCULATED	(1)(2)(8)	kW/kW	8,010	8,070	8,220	8,150	8,100	8,080	8,150	7,990	8,080	8,030
EXCHANGERS												
HEAT EXCHANGER USER SIDE IN REFRIGERATION												
Water flow	(1)(8)	l/s	51,82	58,61	62,33	89,92	117,4	145,9	174,5	33,88	46,87	63,54
Pressure drop	(1)(8)	kPa	60,2	62,3	60,4	66,0	78,6	91,1	82,8	43,9	53,8	42,4
HEAT EXCHANGER SOURCE SIDE IN REFRIGERATION												
Water flow	(1)(8)	l/s	60,71	68,55	72,77	105,1	137,3	170,2	203,3	40,31	55,40	75,56
Pressure drop	(1)(8)	kPa	50,2	50,5	48,7	55,8	51,3	60,1	69,6	47,4	44,1	41,4
CERTIFIED DATA IN EUROVENT												
Cooling capacity	(1)(2)(9)	kW	748,2	857,2	1067	1271	2143	2637	3128	522,3	680,3	978,2
Total power input	(1)(2)(9)	kW	126,6	142,4	178,1	208,4	360,8	436,6	511,1	88,50	112,6	167,2
EER	(1)(2)(9)	kW/kW	5,910	6,020	5,990	6,100	5,940	6,040	6,120	5,900	6,040	5,850
ESEER	(1)(2)(9)	kW/kW	8,530	8,700	8,640	8,800	8,400	8,420	8,500	8,800	8,700	8,530
Cooling energy class			A	A	A	A	A	A	A	A	A	A
HEAT EXCHANGER USER SIDE IN REFRIGERATION												
Pressure drop	(1)(2)(9)	kPa	28,8	30,6	40,8	30,3	60,3	68,6	61,4	24,0	26,0	23,1
HEAT EXCHANGER SOURCE SIDE IN REFRIGERATION												
Pressure drop	(1)(2)(9)	kPa	23,6	24,4	32,3	25,1	38,6	44,4	50,5	24,6	20,5	21,6
REFRIGERANT CIRCUIT												
Compressors nr.		N°	2	2	2	3	4	5	6	2	2	3
No. Circuits		N°	1	1	1	1	1	1	1	1	1	1
Regulation			STEPLESS STEPLESS STEPLESS STEPLESS STEPLESS STEPLESS STEPLESS STEPLESS STEPLESS STEPLESS									
Min. capacity step		%	11,2	13,7	14,5	10,0	7,6	6,1	7,9	16,6	16,9	8,8
Refrigerant			R513A	R513A	R513A	R513A	R513A	R513A	R513A	R513A	R513A	R513A
Refrigerant charge	(11)	kg	422	400	450	814	1017	1319	1696	273	433	583
Oil charge		kg	0,00	0,00	0,00	0,00	0,00	0,00	0,00	0,00	0,00	0,00
Rc (ASHRAE)	(3)(8)(11)	kg/kW	0,39	0,33	0,35	0,44	0,42	0,44	0,47	0,39	0,45	0,44
NOISE LEVEL												
Sound Pressure	(4)	dB(A)	78	78	78	79	79	79	80	76	77	78
Sound power level in cooling	(5)(6)	dB(A)	97	97	97	99	99	100	101	95	96	97
SIZE AND WEIGHT												
A	(7)(10)	mm	3050	3050	3050	4690	4720	5700	6610	2910	3050	3710
B	(7)(10)	mm	1620	1620	1620	1660	1890	2350	2400	1560	1620	1710
H	(7)(10)	mm	2190	2190	2190	2260	2400	2400	2450	2190	2190	2260
Operating weight	(7)(10)	kg	5350	5340	5420	8810	11410	15330	20580	4070	5340	7750

Notes:

- 1 Plant (side) cooling exchanger water (in/out) 12,00°C/7,00°C; Source (side) heat exchanger water (in/out) 30,00°C/35,00°C.
- 2 Values in compliance with EN14511
- 3 Rated in accordance with AHRI Standard 550/590 (2011 with addendum 1).
- 4 Average sound pressure level at 1m distance, unit in a free field on a reflective surface; non-binding value calculated from the sound power level.
- 5 Sound power on the basis of measurements made in compliance with ISO 9614.
- 6 Sound power level in cooling, indoors.
- 7 Unit in standard configuration/execution, without optional accessories.
- 8 Values related to the maximum compressors' rotating speed.
- 9 Values refer to the nominal rotational speed of the compressors.
- 10 Values related to standard layout : diagonal in sizes up to 4 compressors, horizontal in sizes with 5 or 6 compressors
- 11 Nominal value, please refer always to the printed value on the unit data plate.

- Not available

Certified data in EUROVENT



GENERAL TECHNICAL DATA

TR-W-G05-Z

[SI System]

TR-W-G05-Z		2B2A	2B3A	2C00	2C1A	2C1B	2D00	2D1B	2D1C	2D2B	2D2C	
Power supply		V/ph/Hz 400/3/50 400/3/50 400/3/50 400/3/50 400/3/50 400/3/50 400/3/50 400/3/50 400/3/50 400/3/50										
PERFORMANCE												
COOLING ONLY (GROSS VALUE)												
Cooling capacity	(1)(8)	kW	1680	2049	1131	1489	1621	1471	1966	2045	2460	2614
Total power input	(1)(8)	kW	314,4	375,6	198,3	266,0	286,6	243,9	332,4	342,1	420,7	441,1
EER	(1)(8)	kW/kW	5,344	5,455	5,703	5,598	5,656	6,031	5,915	5,978	5,847	5,926
ESEER CALCULATED	(1)(8)	kW/kW	9,690	9,900	10,10	9,890	9,840	10,10	9,890	10,00	9,820	9,960
COOLING ONLY (EN14511 VALUE)												
Cooling capacity	(1)(2)(8)	kW	1672	2038	1127	1483	1615	1465	1957	2036	2448	2601
EER	(1)(2)(8)	kW/kW	5,090	5,150	5,470	5,340	5,400	5,710	5,590	5,650	5,530	5,610
ESEER EN14511 CALCULATED	(1)(2)(8)	kW/kW	7,880	7,800	8,450	8,130	8,170	8,120	7,950	8,050	7,940	8,080
EXCHANGERS												
HEAT EXCHANGER USER SIDE IN REFRIGERATION												
Water flow	(1)(8)	l/s	80,33	97,98	54,07	71,21	77,52	70,36	94,02	97,81	117,6	125,0
Pressure drop	(1)(8)	kPa	73,6	90,8	51,2	61,8	60,7	66,7	75,6	74,4	82,5	81,0
HEAT EXCHANGER SOURCE SIDE IN REFRIGERATION												
Water flow	(1)(8)	l/s	95,04	115,6	63,37	83,67	90,95	81,82	109,6	113,9	137,4	145,7
Pressure drop	(1)(8)	kPa	50,3	58,8	41,1	49,9	48,2	55,5	60,7	58,8	56,2	52,3
CERTIFIED DATA IN EUROVENT												
Cooling capacity	(1)(2)(9)	kW	1240	1674	916,7	1123	1221	984,1	1448	1848	2185	2332
Total power input	(1)(2)(9)	kW	208,1	284,2	151,3	184,1	199,8	168,2	240,9	312,2	371,0	391,9
EER	(1)(2)(9)	kW/kW	5,960	5,890	6,060	6,100	6,110	5,850	6,010	5,920	5,890	5,950
ESEER	(1)(2)(9)	kW/kW	8,470	8,300	8,910	8,600	8,640	8,780	8,410	8,250	8,170	8,320
Cooling energy class			A	A	A	A	A	A	A	A	A	A
HEAT EXCHANGER USER SIDE IN REFRIGERATION												
Pressure drop	(1)(2)(9)	kPa	40,4	61,1	33,8	35,3	34,6	30,0	41,2	61,2	65,6	65,0
HEAT EXCHANGER SOURCE SIDE IN REFRIGERATION												
Pressure drop	(1)(2)(9)	kPa	26,5	38,3	26,5	27,6	26,7	25,0	32,7	47,9	44,1	41,4
REFRIGERANT CIRCUIT												
Compressors nr.		N°	4	5	2	3	3	2	3	3	4	4
No. Circuits		N°	1	1	1	1	1	1	1	1	1	1
Regulation			STEPLESS STEPLESS STEPLESS STEPLESS STEPLESS STEPLESS STEPLESS STEPLESS STEPLESS STEPLESS									
Min. capacity step		%	6,9	5,7	16,5	7,7	10,3	22,0	8,5	9,1	6,7	7,1
Refrigerant			R513A R513A R513A R513A R513A R513A R513A R513A R513A R513A R513A									
Refrigerant charge	(11)	kg	1015	1303	411	751	795	429	814	812	1013	1094
Oil charge		kg	0,00	0,00	0,00	0,00	0,00	0,00	0,00	0,00	0,00	0,00
Rc (ASHRAE)	(3)(8)(11)	kg/kW	0,61	0,64	0,37	0,51	0,50	0,29	0,42	0,40	0,42	0,42
NOISE LEVEL												
Sound Pressure	(4)	dB(A)	78	78	78	78	78	79	79	79	79	80
Sound power level in cooling	(5)(6)	dB(A)	98	99	97	98	98	98	99	99	99	100
SIZE AND WEIGHT												
A	(7)(10)	mm	4720	5700	3050	4690	4690	3050	4690	4690	4720	4720
B	(7)(10)	mm	1890	2350	1620	1660	1660	1620	1660	1660	1890	1890
H	(7)(10)	mm	2400	2400	2190	2260	2260	2190	2260	2260	2400	2400
Operating weight	(7)(10)	kg	10610	13850	5330	8470	8700	5310	8810	8880	11250	11450

Notes:

- 1 Plant (side) cooling exchanger water (in/out) 12,00°C/7,00°C; Source (side) heat exchanger water (in/out) 30,00°C/35,00°C.
- 2 Values in compliance with EN14511
- 3 Rated in accordance with AHRI Standard 550/590 (2011 with addendum 1).
- 4 Average sound pressure level at 1m distance, unit in a free field on a reflective surface; non-binding value calculated from the sound power level.
- 5 Sound power on the basis of measurements made in compliance with ISO 9614.
- 6 Sound power level in cooling, indoors.
- 7 Unit in standard configuration/execution, without optional accessories.
- 8 Values related to the maximum compressors' rotating speed.
- 9 Values refer to the nominal rotational speed of the compressors.
- 10 Values related to standard layout : diagonal in sizes up to 4 compressors, horizontal in sizes with 5 or 6 compressors
- 11 Nominal value, please refer always to the printed value on the unit data plate.

- Not available

Certified data in EUROVENT

GENERAL TECHNICAL DATA

TR-W-G05-Z

[SI System]

TR-W-G05-Z		2D3C	2D4C	3A00	3B00	3B1A	3B2A	3B3A	3C00	3C1A	3C1B	
Power supply		V/ph/Hz 400/3/50 400/3/50 400/3/50 400/3/50 400/3/50 400/3/50 400/3/50 400/3/50 400/3/50 400/3/50										
PERFORMANCE												
COOLING ONLY (GROSS VALUE)												
Cooling capacity	(1)(8)	kW	3210	3817	1050	1462	1819	2174	2531	1709	2059	2187
Total power input	(1)(8)	kW	538,6	631,4	210,8	280,6	338,1	400,2	460,0	297,6	366,1	384,7
EER	(1)(8)	kW/kW	5,960	6,045	4,981	5,210	5,380	5,432	5,502	5,743	5,624	5,685
ESEER CALCULATED	(1)(8)	kW/kW	10,10	10,30	9,320	9,410	9,630	9,750	9,890	10,00	9,820	9,840
COOLING ONLY (EN14511 VALUE)												
Cooling capacity	(1)(2)(8)	kW	3193	3798	1047	1458	1811	2163	2519	1702	2050	2177
EER	(1)(2)(8)	kW/kW	5,610	5,690	4,800	5,030	5,130	5,140	5,200	5,480	5,360	5,420
ESEER EN14511 CALCULATED	(1)(2)(8)	kW/kW	8,010	8,160	7,880	8,060	7,880	7,770	7,870	8,280	8,090	8,130
EXCHANGERS												
HEAT EXCHANGER USER SIDE IN REFRIGERATION												
Water flow	(1)(8)	l/s	153,5	182,5	50,20	69,91	86,99	104,0	121,0	81,72	98,48	104,6
Pressure drop	(1)(8)	kPa	94,7	86,4	44,1	42,4	72,6	88,3	81,6	60,6	71,6	70,9
HEAT EXCHANGER SOURCE SIDE IN REFRIGERATION												
Water flow	(1)(8)	l/s	178,8	212,2	60,04	83,03	102,8	122,7	142,6	95,68	115,6	122,6
Pressure drop	(1)(8)	kPa	62,2	70,0	42,5	42,0	49,3	58,5	65,9	49,8	48,5	46,8
CERTIFIED DATA IN EUROVENT												
Cooling capacity	(1)(2)(9)	kW	2823	3320	723,3	1078	1344	1790	2070	1301	1738	1854
Total power input	(1)(2)(9)	kW	469,7	541,6	124,1	184,3	225,1	307,0	349,7	210,9	292,6	310,6
EER	(1)(2)(9)	kW/kW	6,010	6,130	5,830	5,850	5,970	5,830	5,920	6,170	5,940	5,970
ESEER	(1)(2)(9)	kW/kW	8,300	8,480	8,650	8,610	8,430	8,190	8,330	8,820	8,420	8,480
Cooling energy class			A	A	A	A	A	A	A	A	A	A
HEAT EXCHANGER USER SIDE IN REFRIGERATION												
Pressure drop	(1)(2)(9)	kPa	73,8	65,9	21,0	23,2	39,8	60,3	55,0	35,3	51,4	51,3
HEAT EXCHANGER SOURCE SIDE IN REFRIGERATION												
Pressure drop	(1)(2)(9)	kPa	47,7	52,5	19,2	22,0	26,1	38,7	42,9	28,2	33,9	33,0
REFRIGERANT CIRCUIT												
Compressors nr.		N°	5	6	3	3	4	5	6	3	4	4
No. Circuits		N°	1	1	1	1	1	1	1	1	1	1
Regulation			STEPLESS STEPLESS STEPLESS STEPLESS STEPLESS STEPLESS STEPLESS STEPLESS STEPLESS STEPLESS									
Min. capacity step		%	5,8	4,9	11,2	11,3	6,4	5,3	4,9	10,8	5,5	7,5
Refrigerant			R513A R513A R513A R513A R513A R513A R513A R513A R513A R513A R513A									
Refrigerant charge	(11)	kg	1299	1667	501	598	985	1269	1677	795	1078	1013
Oil charge		kg	0,00	0,00	0,00	0,00	0,00	0,00	0,00	0,00	0,00	0,00
Rc (ASHRAE)	(3)(8)(11)	kg/kW	0,41	0,44	0,48	0,41	0,55	0,59	0,67	0,47	0,53	0,47
NOISE LEVEL												
Sound Pressure	(4)	dB(A)	79	80	77	78	78	78	79	78	79	79
Sound power level in cooling	(5)(6)	dB(A)	100	101	96	97	98	99	100	98	99	99
SIZE AND WEIGHT												
A	(7)(10)	mm	5700	6610	3710	3710	4720	5700	6610	4690	4720	4720
B	(7)(10)	mm	2350	2400	1710	1710	1890	2350	2400	1660	1890	1890
H	(7)(10)	mm	2400	2450	2260	2260	2400	2400	2450	2260	2400	2400
Operating weight	(7)(10)	kg	15420	20750	7440	7370	10740	14050	18670	8700	11010	11210

Notes:

- 1 Plant (side) cooling exchanger water (in/out) 12,00°C/7,00°C; Source (side) heat exchanger water (in/out) 30,00°C/35,00°C.
- 2 Values in compliance with EN14511
- 3 Rated in accordance with AHRI Standard 550/590 (2011 with addendum 1).
- 4 Average sound pressure level at 1m distance, unit in a free field on a reflective surface; non-binding value calculated from the sound power level.
- 5 Sound power on the basis of measurements made in compliance with ISO 9614.
- 6 Sound power level in cooling, indoors.
- 7 Unit in standard configuration/execution, without optional accessories.
- 8 Values related to the maximum compressors' rotating speed.
- 9 Values refer to the nominal rotational speed of the compressors.
- 10 Values related to standard layout : diagonal in sizes up to 4 compressors, horizontal in sizes with 5 or 6 compressors
- 11 Nominal value, please refer always to the printed value on the unit data plate.

- Not available

Certified data in EUROVENT

GENERAL TECHNICAL DATA

TR-W-G05-Z

[SI System]

TR-W-G05-Z		3C2B	3D00	3D1A	3D1C	3D2C	3D3C	4B00	4B1A	4B2A	4C00	
Power supply		V/ph/Hz 400/3/50 400/3/50 400/3/50 400/3/50 400/3/50 400/3/50 400/3/50 400/3/50 400/3/50 400/3/50										
PERFORMANCE												
COOLING ONLY (GROSS VALUE)												
Cooling capacity	(1)(8)	kW	2705	2213	2563	2792	3388	3990	1952	2314	2679	2277
Total power input	(1)(8)	kW	470,3	364,9	432,9	460,5	557,8	647,3	357,9	419,9	476,5	396,2
EER	(1)(8)	kW/kW	5,752	6,065	5,921	6,063	6,074	6,164	5,454	5,511	5,622	5,747
ESEER CALCULATED	(1)(8)	kW/kW	9,990	10,00	9,780	10,00	10,10	10,40	9,680	9,790	10,00	10,00
COOLING ONLY (EN14511 VALUE)												
Cooling capacity	(1)(2)(8)	kW	2692	2202	2550	2778	3369	3970	1943	2302	2666	2267
EER	(1)(2)(8)	kW/kW	5,440	5,710	5,580	5,720	5,690	5,790	5,200	5,220	5,310	5,470
ESEER EN14511 CALCULATED	(1)(2)(8)	kW/kW	8,030	7,980	7,840	8,050	7,950	8,190	7,960	7,830	7,930	8,190
EXCHANGERS												
HEAT EXCHANGER USER SIDE IN REFRIGERATION												
Water flow	(1)(8)	l/s	129,4	105,9	122,6	133,5	162,0	190,8	93,35	110,7	128,1	108,9
Pressure drop	(1)(8)	kPa	82,4	78,4	89,6	85,5	98,7	89,6	71,1	85,7	82,9	70,7
HEAT EXCHANGER SOURCE SIDE IN REFRIGERATION												
Water flow	(1)(8)	l/s	151,4	123,0	142,9	155,1	188,3	221,2	110,1	130,3	150,4	127,5
Pressure drop	(1)(8)	kPa	59,4	64,7	58,2	56,2	68,9	69,8	48,7	57,2	67,4	48,5
CERTIFIED DATA IN EUROVENT												
Cooling capacity	(1)(2)(9)	kW	2277	2043	2326	2536	3027	3518	1443	1918	2200	1488
Total power input	(1)(2)(9)	kW	377,6	348,0	398,3	425,5	503,7	570,2	239,7	326,2	366,7	240,4
EER	(1)(2)(9)	kW/kW	6,030	5,870	5,840	5,960	6,010	6,170	6,020	5,880	6,000	6,190
ESEER	(1)(2)(9)	kW/kW	8,410	8,160	7,990	8,240	8,210	8,480	8,510	8,240	8,370	8,860
Cooling energy class			A	A	A	A	A	A	A	A	A	A
HEAT EXCHANGER USER SIDE IN REFRIGERATION												
Pressure drop	(1)(2)(9)	kPa	58,8	67,4	74,5	71,1	79,5	70,2	39,1	59,3	56,3	30,3
HEAT EXCHANGER SOURCE SIDE IN REFRIGERATION												
Pressure drop	(1)(2)(9)	kPa	41,4	55,3	47,9	46,3	54,8	53,9	25,8	38,4	44,5	20,2
REFRIGERANT CIRCUIT												
Compressors nr.		N°	5	3	4	4	5	6	4	5	6	4
No. Circuits		N°	1	1	1	1	1	1	1	1	1	1
Regulation			STEPLESS STEPLESS STEPLESS STEPLESS STEPLESS STEPLESS STEPLESS STEPLESS STEPLESS STEPLESS									
Min. capacity step		%	6,2	14,3	4,6	6,7	5,5	4,7	8,5	5,0	6,2	8,1
Refrigerant			R513A R513A R513A R513A R513A R513A R513A R513A R513A R513A R513A									
Refrigerant charge	(11)	kg	1252	850	1059	1072	1400	1626	1078	1233	1638	1050
Oil charge		kg	0,00	0,00	0,00	0,00	0,00	0,00	0,00	0,00	0,00	0,00
Rc (ASHRAE)	(3)(8)(11)	kg/kW	0,47	0,39	0,42	0,39	0,42	0,41	0,56	0,54	0,62	0,47
NOISE LEVEL												
Sound Pressure	(4)	dB(A)	79	79	80	80	80	80	78	78	79	79
Sound power level in cooling	(5)(6)	dB(A)	100	99	100	100	101	101	98	99	100	99
SIZE AND WEIGHT												
A	(7)(10)	mm	5700	4690	4720	4720	5700	6610	4720	5700	6610	4720
B	(7)(10)	mm	2350	1660	1890	1890	2350	2400	1890	2350	2400	1890
H	(7)(10)	mm	2400	2260	2400	2400	2400	2450	2400	2400	2450	2400
Operating weight	(7)(10)	kg	14910	9010	11250	11580	15500	21010	10920	14300	18880	11250

Notes:

- 1 Plant (side) cooling exchanger water (in/out) 12,00°C/7,00°C; Source (side) heat exchanger water (in/out) 30,00°C/35,00°C.
- 2 Values in compliance with EN14511
- 3 Rated in accordance with AHRI Standard 550/590 (2011 with addendum 1).
- 4 Average sound pressure level at 1m distance, unit in a free field on a reflective surface; non-binding value calculated from the sound power level.
- 5 Sound power on the basis of measurements made in compliance with ISO 9614.
- 6 Sound power level in cooling, indoors.
- 7 Unit in standard configuration/execution, without optional accessories.
- 8 Values related to the maximum compressors' rotating speed.
- 9 Values refer to the nominal rotational speed of the compressors.
- 10 Values related to standard layout : diagonal in sizes up to 4 compressors, horizontal in sizes with 5 or 6 compressors
- 11 Nominal value, please refer always to the printed value on the unit data plate.

- Not available

Certified data in EUROVENT

GENERAL TECHNICAL DATA

TR-W-G05-Z

[SI System]

TR-W-G05-Z		4C1B	4D00	4D1C	4D2C	5B00	5B1A	5C00	5C1B	5D00	5D1C	
Power supply		V/ph/Hz 400/3/50 400/3/50 400/3/50 400/3/50 400/3/50 400/3/50 400/3/50 400/3/50 400/3/50 400/3/50										
PERFORMANCE												
COOLING ONLY (GROSS VALUE)												
Cooling capacity	(1)(8)	kW	2781	2961	3571	4171	2454	2809	2856	3367	3739	4322
Total power input	(1)(8)	kW	477,7	484,9	577,8	670,5	441,3	495,3	489,1	571,5	595,9	687,7
EER	(1)(8)	kW/kW	5,822	6,106	6,180	6,221	5,561	5,671	5,839	5,892	6,275	6,285
ESEER CALCULATED	(1)(8)	kW/kW	10,10	10,00	10,20	10,40	9,790	10,00	10,20	10,20	10,30	10,30
COOLING ONLY (EN14511 VALUE)												
Cooling capacity	(1)(2)(8)	kW	2767	2945	3550	4150	2442	2796	2842	3351	3717	4300
EER	(1)(2)(8)	kW/kW	5,500	5,730	5,780	5,820	5,260	5,360	5,520	5,570	5,850	5,880
ESEER EN14511 CALCULATED	(1)(2)(8)	kW/kW	8,080	7,920	7,950	8,100	7,860	7,950	8,150	8,170	7,940	8,120
EXCHANGERS												
HEAT EXCHANGER USER SIDE IN REFRIGERATION												
Water flow	(1)(8)	l/s	133,0	141,6	170,8	199,5	117,4	134,3	136,6	161,0	178,8	206,7
Pressure drop	(1)(8)	kPa	84,8	93,6	106	92,8	85,7	81,8	84,6	80,6	108	94,1
HEAT EXCHANGER SOURCE SIDE IN REFRIGERATION												
Water flow	(1)(8)	l/s	155,4	164,4	197,9	231,0	138,0	157,5	159,5	187,8	206,9	239,0
Pressure drop	(1)(8)	kPa	59,5	63,0	66,0	76,1	56,8	67,5	56,1	64,0	72,1	74,1
CERTIFIED DATA IN EUROVENT												
Cooling capacity	(1)(2)(9)	kW	2349	2733	3233	3724	2046	2319	2421	2835	3426	3901
Total power input	(1)(2)(9)	kW	386,3	464,0	537,0	607,5	346,8	385,2	398,2	461,0	569,1	636,4
EER	(1)(2)(9)	kW/kW	6,080	5,890	6,020	6,130	5,900	6,020	6,080	6,150	6,020	6,130
ESEER	(1)(2)(9)	kW/kW	8,460	8,070	8,160	8,350	8,270	8,380	8,530	8,540	8,130	8,330
Cooling energy class			A	A	A	A	A	A	A	A	A	A
HEAT EXCHANGER USER SIDE IN REFRIGERATION												
Pressure drop	(1)(2)(9)	kPa	60,9	80,4	87,6	74,6	60,0	56,2	61,2	57,6	91,4	77,4
HEAT EXCHANGER SOURCE SIDE IN REFRIGERATION												
Pressure drop	(1)(2)(9)	kPa	41,7	53,9	54,2	60,5	38,6	45,1	39,7	44,7	60,8	60,4
REFRIGERANT CIRCUIT												
Compressors nr.		N°	5	4	5	6	5	6	5	6	5	6
No. Circuits		N°	1	1	1	1	1	1	1	1	1	1
Regulation			STEPLESS STEPLESS STEPLESS STEPLESS STEPLESS STEPLESS STEPLESS STEPLESS STEPLESS STEPLESS									
Min. capacity step		%	6,0	10,7	5,2	4,5	6,7	5,9	6,4	7,1	8,5	4,3
Refrigerant			R513A R513A R513A R513A R513A R513A R513A R513A R513A R513A R513A									
Refrigerant charge	(11)	kg	1239	1072	1380	1767	1317	1594	1343	1583	1355	1739
Oil charge		kg	0,00	0,00	0,00	0,00	0,00	0,00	0,00	0,00	0,00	0,00
Rc (ASHRAE)	(3)(8)(11)	kg/kW	0,45	0,37	0,39	0,43	0,54	0,57	0,48	0,48	0,37	0,41
NOISE LEVEL												
Sound Pressure	(4)	dB(A)	79	80	80	80	78	79	79	80	80	81
Sound power level in cooling	(5)(6)	dB(A)	100	100	101	101	99	100	100	101	101	102
SIZE AND WEIGHT												
A	(7)(10)	mm	5700	4720	5700	6610	5700	6610	5700	6610	5700	6610
B	(7)(10)	mm	2350	1890	2350	2400	2350	2400	2350	2400	2350	2400
H	(7)(10)	mm	2400	2400	2400	2450	2400	2450	2400	2450	2400	2450
Operating weight	(7)(10)	kg	15000	11580	15730	21180	14550	19150	15180	20240	15890	21350

Notes:

- 1 Plant (side) cooling exchanger water (in/out) 12,00°C/7,00°C; Source (side) heat exchanger water (in/out) 30,00°C/35,00°C.
- 2 Values in compliance with EN14511
- 3 Rated in accordance with AHRI Standard 550/590 (2011 with addendum 1).
- 4 Average sound pressure level at 1m distance, unit in a free field on a reflective surface; non-binding value calculated from the sound power level.
- 5 Sound power on the basis of measurements made in compliance with ISO 9614.
- 6 Sound power level in cooling, indoors.
- 7 Unit in standard configuration/execution, without optional accessories.
- 8 Values related to the maximum compressors' rotating speed.
- 9 Values refer to the nominal rotational speed of the compressors.
- 10 Values related to standard layout : diagonal in sizes up to 4 compressors, horizontal in sizes with 5 or 6 compressors
- 11 Nominal value, please refer always to the printed value on the unit data plate.

- Not available

Certified data in EUROVENT



GENERAL TECHNICAL DATA

TR-W-G05-Z

[SI System]

TR-W-G05-Z		6B00	6C00	6D00	
Power supply		V/ph/Hz	400/3/50	400/3/50	400/3/50
PERFORMANCE					
COOLING ONLY (GROSS VALUE)					
Cooling capacity	(1)(8)	kW	2935	3458	4490
Total power input	(1)(8)	kW	515,3	585,8	707,4
EER	(1)(8)	kW/kW	5,696	5,903	6,347
ESEER CALCULATED	(1)(8)	kW/kW	9,940	10,20	10,40
COOLING ONLY (EN14511 VALUE)					
Cooling capacity	(1)(2)(8)	kW	2921	3442	4466
EER	(1)(2)(8)	kW/kW	5,380	5,580	5,930
ESEER EN14511 CALCULATED	(1)(2)(8)	kW/kW	7,940	8,210	8,080
EXCHANGERS					
HEAT EXCHANGER USER SIDE IN REFRIGERATION					
Water flow	(1)(8)	l/s	140,4	165,4	214,7
Pressure drop	(1)(8)	kPa	81,7	81,5	95,6
HEAT EXCHANGER SOURCE SIDE IN REFRIGERATION					
Water flow	(1)(8)	l/s	164,5	192,8	248,0
Pressure drop	(1)(8)	kPa	66,7	62,7	79,7
CERTIFIED DATA IN EUROVENT					
Cooling capacity	(1)(2)(9)	kW	2434	2919	4092
Total power input	(1)(2)(9)	kW	404,3	474,6	669,7
EER	(1)(2)(9)	kW/kW	6,020	6,150	6,110
ESEER	(1)(2)(9)	kW/kW	8,360	8,600	8,270
Cooling energy class			A	A	A
HEAT EXCHANGER USER SIDE IN REFRIGERATION					
Pressure drop	(1)(2)(9)	kPa	56,6	58,5	80,2
HEAT EXCHANGER SOURCE SIDE IN REFRIGERATION					
Pressure drop	(1)(2)(9)	kPa	44,9	43,9	66,5
REFRIGERANT CIRCUIT					
Compressors nr.		N°	6	6	6
No. Circuits		N°	1	1	1
Regulation			STEPLESS	STEPLESS	STEPLESS
Min. capacity step		%	8,1	8,2	7,0
Refrigerant			R513A	R513A	R513A
Refrigerant charge	(11)	kg	1722	1555	1699
Oil charge		kg	0,00	0,00	0,00
Rc (ASHRAE)	(3)(8)(11)	kg/kW	0,59	0,45	0,38
NOISE LEVEL					
Sound Pressure	(4)	dB(A)	79	80	81
Sound power level in cooling	(5)(6)	dB(A)	100	101	102
SIZE AND WEIGHT					
A	(7)(10)	mm	6610	6610	6610
B	(7)(10)	mm	2400	2400	2400
H	(7)(10)	mm	2450	2450	2450
Operating weight	(7)(10)	kg	19400	20410	21560

Notes:

- 1 Plant (side) cooling exchanger water (in/out) 12,00°C/7,00°C; Source (side) heat exchanger water (in/out) 30,00°C/35,00°C.
- 2 Values in compliance with EN14511
- 3 Rated in accordance with AHRI Standard 550/590 (2011 with addendum 1).
- 4 Average sound pressure level at 1m distance, unit in a free field on a reflective surface; non-binding value calculated from the sound power level.
- 5 Sound power on the basis of measurements made in compliance with ISO 9614.
- 6 Sound power level in cooling, indoors.
- 7 Unit in standard configuration/execution, without optional accessories.
- 8 Values related to the maximum compressors' rotating speed.
- 9 Values refer to the nominal rotational speed of the compressors.
- 10 Values related to standard layout : diagonal in sizes up to 4 compressors, horizontal in sizes with 5 or 6 compressors
- 11 Nominal value, please refer always to the printed value on the unit data plate.

- Not available

Certified data in EUROVENT

6.1 TECHNICAL DATA SEASONAL EFFICIENCY IN COOLING (EN14825 VALUE)

[SI System]

ENERGY EFFICIENCY

SEASONAL EFFICIENCY IN COOLING (Reg. EU 2016/2281)

Process refrigeration at high temperature

TR-W-G05-Z			1A00	1B00	1B1A	1B2A	1B3A	1C00	1C1A	1C1B	1C3B	1D00
Prated,c	(1)	kW	243,65	364,40	581,90	818,87	1143,00	458,90	642,50	737,05	1708,00	658,50
SEPR	(1) (3)	-	11,62	11,56	11,64	11,41	11,57	11,49	11,75	11,58	10,96	11,55
TR-W-G05-Z			1D1A	1D1B	1D1C	1D2C	1D3C	1D4C	1D5C	2A00	2B00	2B1A
Prated,c	(1)	kW	748,17	857,16	1066,85	1271,00	2142,87	2637,00	3128,00	522,30	680,30	978,20
SEPR	(1) (3)	-	11,60	11,58	11,51	11,88	11,07	11,23	11,33	11,55	11,48	11,26
TR-W-G05-Z			2B2A	2B3A	2C00	2C1A	2C1B	2D00	2D1B	2D1C	2D2B	2D2C
Prated,c	(1)	kW	1240,00	1674,00	916,70	1123,00	1220,93	984,10	1447,86	1847,77	2185,00	2331,65
SEPR	(1) (3)	-	11,45	11,50	11,37	11,56	11,55	11,63	11,54	11,25	11,11	11,20
TR-W-G05-Z			2D3C	2D4C	3A00	3B00	3B1A	3B2A	3B3A	3C00	3C1A	3C1B
Prated,c	(1)	kW	2822,60	3320,00	723,30	1078,00	1344,00	1790,00	2069,74	1300,70	1738,00	1853,79
SEPR	(1) (3)	-	11,25	11,47	11,33	11,24	11,42	11,42	11,60	11,71	11,02	11,11
TR-W-G05-Z			3C2B	3D00	3D1A	3D1C	3D2C	3D3C	4B00	4B1A	4B2A	4C00
Prated,c	(1)	kW	2276,61	2043,00	2326,00	2536,00	3026,91	3517,58	1443,00	1917,73	2200,00	1487,76
SEPR	(1) (3)	-	11,18	11,29	11,12	11,32	11,31	11,59	11,47	11,53	11,53	11,95
TR-W-G05-Z			4C1B	4D00	4D1C	4D2C	5B00	5B1A	5C00	5C1B	5D00	5D1C
Prated,c	(1)	kW	2349,00	2733,00	3232,70	3723,99	2046,00	2318,82	2420,83	2835,00	3426,00	3900,77
SEPR	(1) (3)	-	11,26	11,22	11,41	11,56	11,58	11,55	11,29	11,40	11,45	11,65
TR-W-G05-Z			6B00	6C00	6D00							
Prated,c	(1)	kW	2434,00	2918,61	4092,00							
SEPR	(1) (3)	-	11,54	11,41	11,63							

SEASONAL EFFICIENCY IN COOLING (Reg. EU 2015/1095)

Process refrigeration at medium temperature

Notes:

(1) Seasonal energy efficiency of high temperature process cooling [REGULATION (EU) N. 2016/2281]

(2) Seasonal Energy Efficiency of Process Cooling at Medium Temperature [REGULATION (EU) N. 2015/1095]

(3) Seasonal energy efficiency ratio

The units highlighted in this publication contain R513A [GWP₁₀₀ 631] fluorinated greenhouse gases.

Certified data in EUROVENT

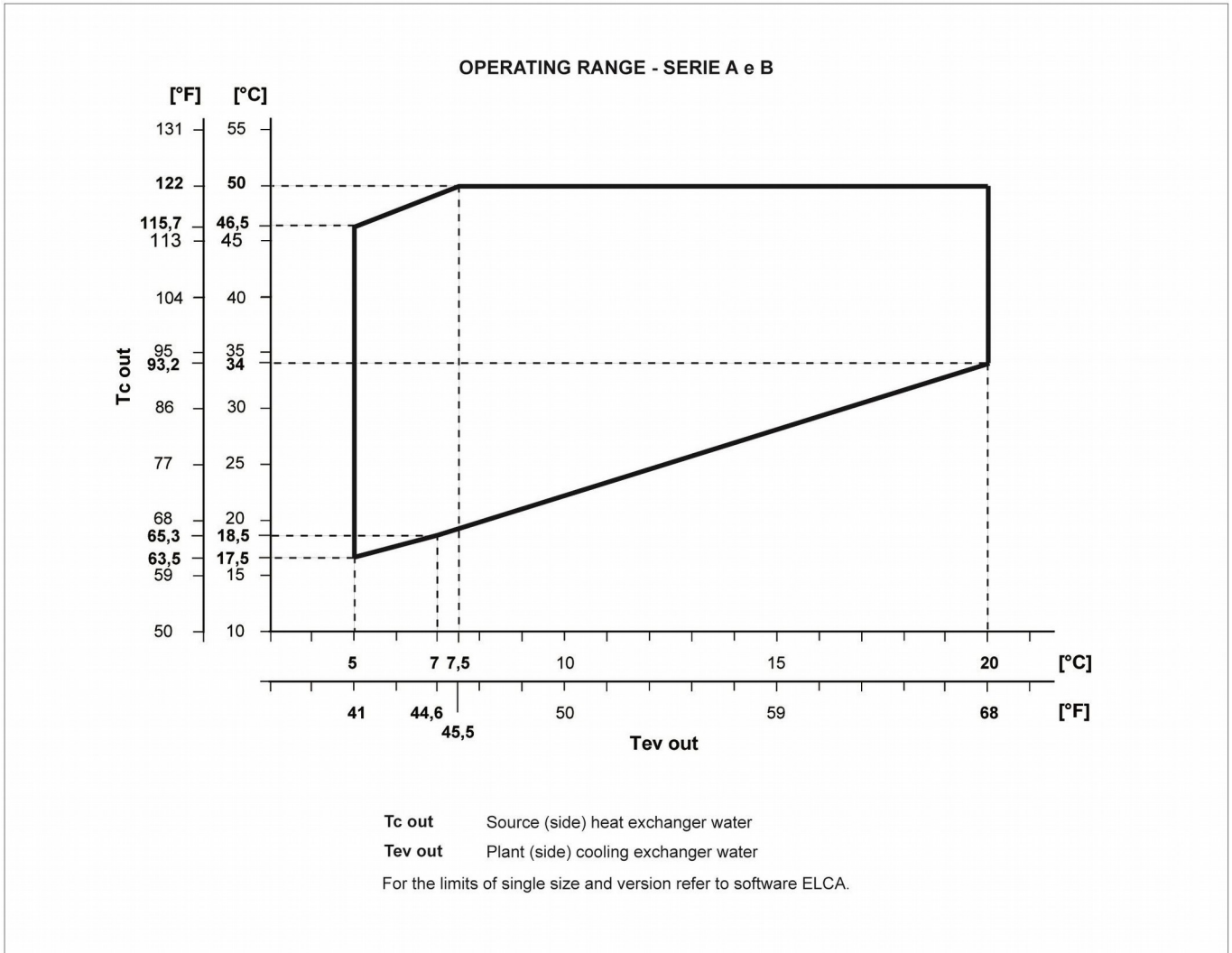

SIZE
TR-W-G05-Z /1A00
TR-W-G05-Z /1B00
TR-W-G05-Z /1B1A
TR-W-G05-Z /1B2A
TR-W-G05-Z /1B3A
TR-W-G05-Z /2A00
TR-W-G05-Z /2B00
TR-W-G05-Z /2B1A
TR-W-G05-Z /2B2A
TR-W-G05-Z /2B3A
TR-W-G05-Z /3A00
TR-W-G05-Z /3B00
TR-W-G05-Z /3B1A
TR-W-G05-Z /3B2A
TR-W-G05-Z /3B3A
TR-W-G05-Z /4B00
TR-W-G05-Z /4B1A
TR-W-G05-Z /4B2A
TR-W-G05-Z /5B00
TR-W-G05-Z /5B1A
TR-W-G05-Z /6B00

OPERATING RANGE - SERIE C

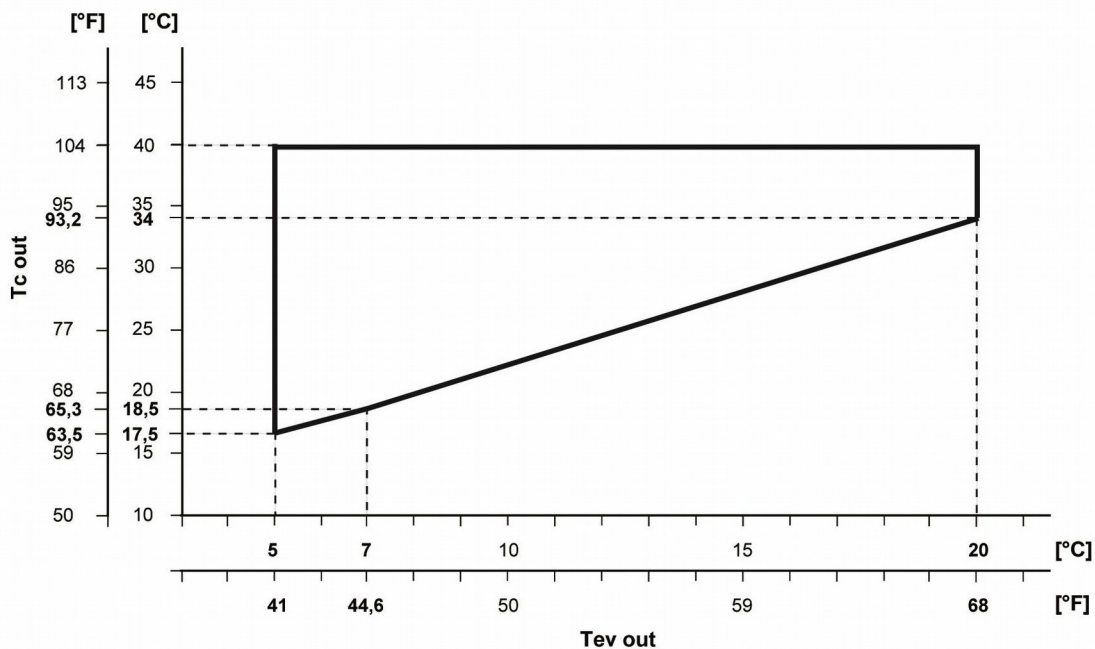

Tc out Source (side) heat exchanger water
 Tev out Plant (side) cooling exchanger water
 For the limits of single size and version refer to software ELCA.

SIZE
TR-W-G05-Z /1C00
TR-W-G05-Z /1C1A
TR-W-G05-Z /1C1B
TR-W-G05-Z /1C3B
TR-W-G05-Z /2C00
TR-W-G05-Z /2C1A
TR-W-G05-Z /2C1B
TR-W-G05-Z /3C00
TR-W-G05-Z /3C1A
TR-W-G05-Z /3C1B
TR-W-G05-Z /3C2B
TR-W-G05-Z /4C00
TR-W-G05-Z /4C1B
TR-W-G05-Z /5C00
TR-W-G05-Z /5C1B
TR-W-G05-Z /6C00

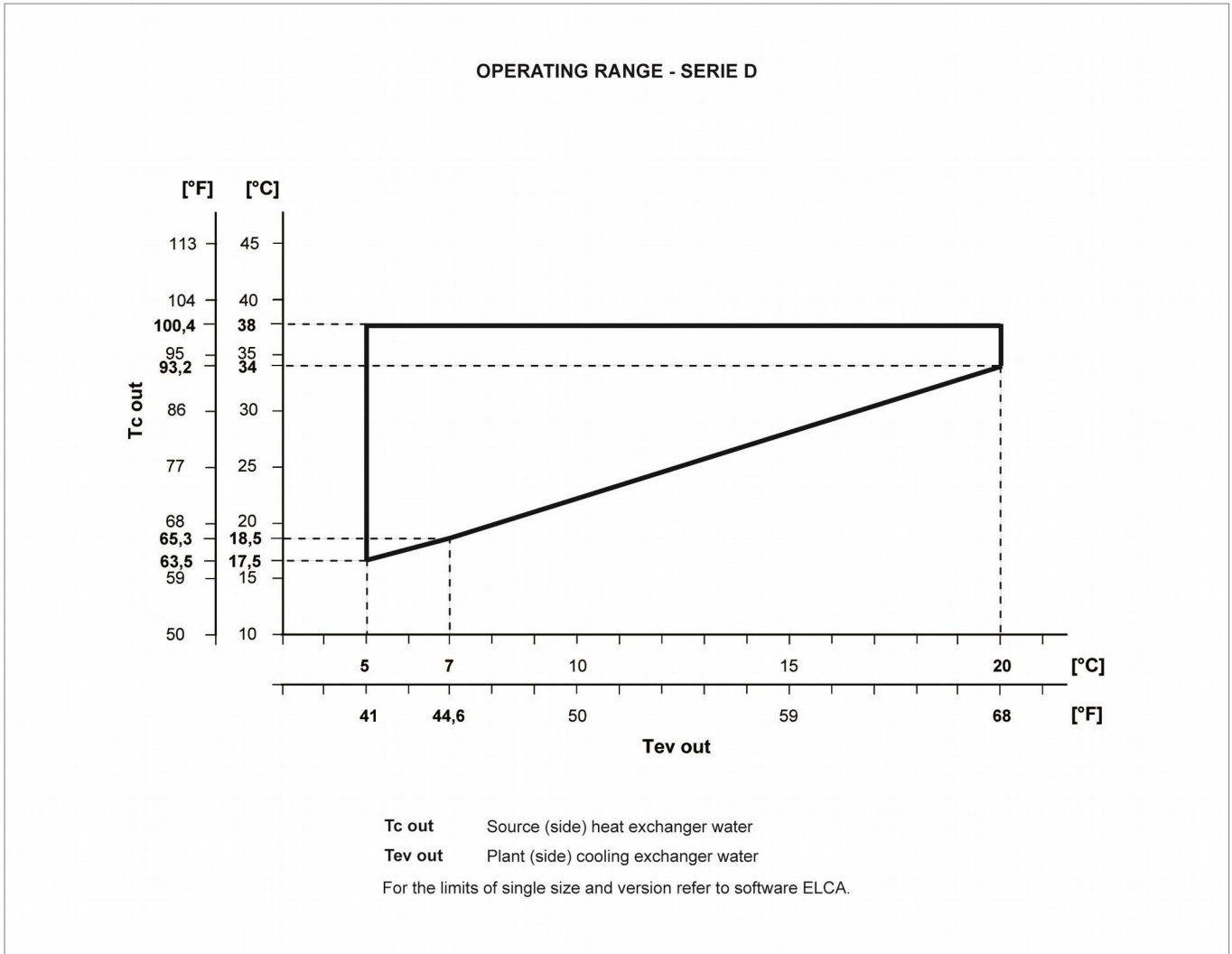

SIZE	
TR-W-G05-Z /1D00	TR-W-G05-Z /4D2C
TR-W-G05-Z /1D1A	TR-W-G05-Z /5D00
TR-W-G05-Z /1D1B	TR-W-G05-Z /5D1C
TR-W-G05-Z /1D1C	TR-W-G05-Z /6D00
TR-W-G05-Z /1D2C	
TR-W-G05-Z /1D3C	
TR-W-G05-Z /1D4C	
TR-W-G05-Z /1D5C	
TR-W-G05-Z /2D00	
TR-W-G05-Z /2D1B	
TR-W-G05-Z /2D1C	
TR-W-G05-Z /2D2B	
TR-W-G05-Z /2D2C	
TR-W-G05-Z /2D3C	
TR-W-G05-Z /2D4C	
TR-W-G05-Z /3D00	
TR-W-G05-Z /3D1A	
TR-W-G05-Z /3D1C	
TR-W-G05-Z /3D2C	
TR-W-G05-Z /3D3C	
TR-W-G05-Z /4D00	
TR-W-G05-Z /4D1C	

7.2 ETHYLENE GLYCOL MIXTURE

Ethylene glycol and water mixture, used as a heat-conveying fluid, cause a variation in unit performance. For correct data, use the factors indicated in the following tabel.

	Freezing point (°C)							
	0	-5	-10	-15	-20	-25	-30	-35
	Ethylene glycol percentage by weight							
	0%	12%	20%	30%	35%	40%	45%	50%
cPf	1	0,985	0,98	0,974	0,97	0,965	0,964	0,96
cQ	1	1,02	1,04	1,075	1,11	1,14	1,17	1,2
cdp	1	1,07	1,11	1,18	1,22	1,24	1,27	1,3

cPf: cooling power correction factor
 cQ: flow correction factor
 cdp: pressure drop correction factor

For data concerning other kind of anti-freeze solutions (e.g. propylene glycol) please contact our Sale Department.

7.3 FOULING FACTORS

Performances are based on clean condition of tubes (fouling factor = 1). For different fouling values, performance should be adjusted using the correction factors shown in the following table.

SERIES	FOULING FACTORS	EVAPORATOR			CONDENSER/RECOVERY			DESUPERHEATER
	ff (m ² °CW)	F1	FK1	KE [°C]	F2	FK2	KC [°C]	R3
VARIOUS	0	1,000	1,000	0,0	1,000	1,000	0,0	1,000
VARIOUS	1,80 x 10 ⁻⁵	1,000	1,000	0,0	1,000	1,000	0,0	1,000
VARIOUS	4,40 x 10 ⁻⁵	1,000	1,000	0,0	0,990	1,030	1,0	0,990
VARIOUS	8,80 x 10 ⁻⁵	0,960	0,990	0,7	0,980	1,040	1,5	0,980
VARIOUS	13,20 x 10 ⁻⁵	0,944	0,985	1,0	0,964	1,050	2,3	0,964
VARIOUS	17,20 x 10 ⁻⁵	0,930	0,980	1,5	0,950	1,060	3,0	0,950

ff: fouling factors
 F1 - F2: potential correction factors
 FK1 - FK2: compressor power input correction factors
 R3: capacity correction factors
 KE: minimum evaporator outlet temperature increase
 KC: maximum condenser outlet temperature decrease

8.1 HYDRAULIC DATA

[SI System]

Water flow and pressure drop

Water flow in the plant (side) exchanger is given by:

$$Q = P / (4,186 \times Dt)$$

Q: water flow (l/s)

Dt: difference between inlet and outlet water temp. (°C)

P: heat exchanger capacity (kW)

Pressure drop is given by:

$$Dp = K \times (3,6 \times Q)^2 / 1000$$

Q: water flow (l/s)

Dp: pressure drop (kPa)

K: unit size ratio

SIZE	Power supply V/ph/Hz	HEAT EXCHANGER USER SIDE					HEAT EXCHANGER SOURCE SIDE			
		K	Q min l/s	Q max l/s	C.A.S. l	C.a. min l	K [1]	Q min [2] l/s	Q max l/s	C.A.S. l
TR-W-G05-Z /1A00	400/3/50	10,7	9,722	24,44	82,0	5000	7,34	11,67	29,17	82,0
TR-W-G05-Z /1B00	400/3/50	5,52	13,89	33,33	104	5000	3,87	15,83	40,00	112
TR-W-G05-Z /1B1A	400/3/50	2,55	20,00	50,00	164	5000	1,53	25,56	64,17	175
TR-W-G05-Z /1B2A	400/3/50	1,06	30,56	69,72	230	5000	0,72	33,61	83,89	295
TR-W-G05-Z /1B3A	400/3/50	0,88	33,89	85,28	340	5000	0,50	44,44	111,4	455
TR-W-G05-Z /1C00	400/3/50	3,84	16,67	40,28	120	5000	2,80	18,61	47,22	132
TR-W-G05-Z /1C1A	400/3/50	2,09	21,94	54,72	176	5000	1,24	28,61	71,67	195
TR-W-G05-Z /1C1B	400/3/50	1,59	25,56	62,78	196	5000	0,93	32,78	82,22	225
TR-W-G05-Z /1C3B	400/3/50	0,60	41,11	103,3	413	5000	0,29	58,89	147,2	610
TR-W-G05-Z /1D00	400/3/50	3,00	18,61	45,83	132	5000	2,20	21,11	53,33	152
TR-W-G05-Z /1D1A	400/3/50	1,73	24,17	60,56	189	5000	1,05	30,83	77,50	210
TR-W-G05-Z /1D1B	400/3/50	1,40	26,67	66,67	204	5000	0,83	34,72	86,94	240
TR-W-G05-Z /1D1C	400/3/50	1,20	28,89	72,22	220	5000	0,71	37,78	94,44	260
TR-W-G05-Z /1D2C	400/3/50	0,63	40,28	100,6	400	5000	0,39	50,83	126,9	520
TR-W-G05-Z /1D3C	400/3/50	0,44	48,61	121,7	463	5000	0,21	69,17	173,3	700
TR-W-G05-Z /1D4C	400/3/50	0,33	59,72	149,7	871	5000	0,16	85,00	213,3	1480
TR-W-G05-Z /1D5C	400/3/50	0,21	79,17	188,9	1360	5000	0,13	101,4	250,0	1829
TR-W-G05-Z /2A00	400/3/50	2,95	18,61	45,83	132	5000	2,25	21,11	53,33	152
TR-W-G05-Z /2B00	400/3/50	1,89	23,06	57,50	184	5000	1,11	30,00	75,00	205
TR-W-G05-Z /2B1A	400/3/50	0,81	35,00	80,00	258	5000	0,56	38,06	95,83	325
TR-W-G05-Z /2B2A	400/3/50	0,88	33,89	85,28	358	5000	0,43	48,06	120,3	490
TR-W-G05-Z /2B3A	400/3/50	0,73	40,28	100,8	658	5000	0,34	58,33	145,8	1080
TR-W-G05-Z /2C00	400/3/50	1,35	27,50	68,06	209	5000	0,79	35,83	89,44	245
TR-W-G05-Z /2C1A	400/3/50	0,94	32,78	83,33	330	5000	0,55	42,50	106,9	435
TR-W-G05-Z /2C1B	400/3/50	0,78	36,11	90,28	360	5000	0,45	47,22	118,1	485
TR-W-G05-Z /2D00	400/3/50	1,04	30,83	77,78	227	5000	0,64	39,72	99,17	270
TR-W-G05-Z /2D1B	400/3/50	0,66	39,17	98,33	390	5000	0,39	50,83	126,9	520
TR-W-G05-Z /2D1C	400/3/50	0,60	41,39	103,9	410	5000	0,35	53,33	133,9	550
TR-W-G05-Z /2D2B	400/3/50	0,46	47,22	119,4	448	5000	0,23	66,11	165,8	670
TR-W-G05-Z /2D2C	400/3/50	0,40	50,56	126,7	473	5000	0,19	71,39	180,0	730
TR-W-G05-Z /2D3C	400/3/50	0,31	61,11	155,6	894	5000	0,15	86,39	215,6	1490
TR-W-G05-Z /2D4C	400/3/50	0,20	81,94	193,1	1386	5000	0,12	105,6	255,6	1869
TR-W-G05-Z /3A00	400/3/50	1,35	27,22	61,94	200	5000	0,91	30,00	75,00	265
TR-W-G05-Z /3B00	400/3/50	0,67	38,33	87,78	280	5000	0,47	41,39	105,0	355
TR-W-G05-Z /3B1A	400/3/50	0,74	36,94	93,06	378	5000	0,36	52,78	131,4	540
TR-W-G05-Z /3B2A	400/3/50	0,63	43,06	108,3	692	5000	0,30	61,67	155,0	1130
TR-W-G05-Z /3B3A	400/3/50	0,43	55,56	131,9	1051	5000	0,25	72,78	180,0	1400
TR-W-G05-Z /3C00	400/3/50	0,70	38,33	95,56	380	5000	0,42	48,89	122,5	505

The coefficient "K" on the source side heat exchanger is referred to its standart selection. When it's required to move to an higher number of steps water side (with delta T >=10°C), "K" coefficient as to be multiplied for 8,5 (Knew = K x 8,5)

Q min: minimum water flow admitted to the heat exchanger

Q min [2]: minimum water flow admitted to the heat exchanger

Q max: maximum water flow admitted to the heat exchanger

C.a. min: minimum water content admitted in the plant

C.A.S.: Exchanger water content

HYDRAULIC DATA

[SI System]

SIZE	Power supply V/ph/Hz	HEAT EXCHANGER USER SIDE					HEAT EXCHANGER SOURCE SIDE			
		K	Q min l/s	Q max l/s	C.A.S. l	C.a. min l	K [1]	Q min [2] l/s	Q max l/s	C.A.S. l
TR-W-G05-Z /3C1A	400/3/50	0,57	42,22	106,4	418	5000	0,28	59,72	150,0	620
TR-W-G05-Z /3C1B	400/3/50	0,50	45,56	113,6	438	5000	0,24	64,17	161,1	650
TR-W-G05-Z /3C2B	400/3/50	0,38	55,56	140,0	826	5000	0,20	76,11	190,3	1345
TR-W-G05-Z /3D00	400/3/50	0,54	43,06	108,3	430	5000	0,33	55,56	138,3	570
TR-W-G05-Z /3D1A	400/3/50	0,46	47,22	124,2	448	5000	0,22	67,50	168,6	680
TR-W-G05-Z /3D1C	400/3/50	0,37	52,22	134,7	483	5000	0,18	73,06	183,9	740
TR-W-G05-Z /3D2C	400/3/50	0,29	63,89	163,9	916	5000	0,15	87,50	218,1	1490
TR-W-G05-Z /3D3C	400/3/50	0,19	84,72	200,6	1427	5000	0,11	109,7	263,9	1923
TR-W-G05-Z /4B00	400/3/50	0,63	39,72	100,8	398	5000	0,31	56,11	140,6	580
TR-W-G05-Z /4B1A	400/3/50	0,54	45,83	116,4	726	5000	0,26	66,11	165,8	1200
TR-W-G05-Z /4B2A	400/3/50	0,39	59,72	139,4	1091	5000	0,23	75,00	184,7	1440
TR-W-G05-Z /4C00	400/3/50	0,46	47,22	119,4	448	5000	0,23	66,11	165,8	670
TR-W-G05-Z /4C1B	400/3/50	0,37	56,94	142,2	838	5000	0,19	78,33	195,8	1370
TR-W-G05-Z /4D00	400/3/50	0,36	53,89	142,8	497	5000	0,18	74,17	186,1	750
TR-W-G05-Z /4D1C	400/3/50	0,28	65,28	172,2	927	5000	0,13	92,22	231,9	1600
TR-W-G05-Z /4D2C	400/3/50	0,18	86,67	205,3	1453	5000	0,11	112,5	272,2	1962
TR-W-G05-Z /5B00	400/3/50	0,48	49,44	124,2	759	5000	0,23	71,11	177,2	1270
TR-W-G05-Z /5B1A	400/3/50	0,35	61,94	147,2	1132	5000	0,21	80,00	195,8	1507
TR-W-G05-Z /5C00	400/3/50	0,35	58,33	144,4	849	5000	0,17	82,22	206,4	1440
TR-W-G05-Z /5C1B	400/3/50	0,24	74,44	178,6	1306	5000	0,14	97,22	236,1	1748
TR-W-G05-Z /5D00	400/3/50	0,26	67,50	180,3	952	5000	0,13	95,00	238,3	1640
TR-W-G05-Z /5D1C	400/3/50	0,17	88,89	210,0	1480	5000	0,10	115,3	277,8	2002
TR-W-G05-Z /6B00	400/3/50	0,32	65,00	154,2	1172	5000	0,19	83,33	204,2	1561
TR-W-G05-Z /6C00	400/3/50	0,23	76,94	183,3	1333	5000	0,13	100,0	241,7	1788
TR-W-G05-Z /6D00	400/3/50	0,16	91,67	217,8	1520	5000	0,10	117,2	283,3	2043

The coefficient "K" on the source side heat exchanger is referred to its standart selection. When it's required to move to an higher number of steps water side (with delta T >=10°C), "K" coefficient as to be multiplied for 8,5 (Knew = K x 8,5)

Q min: minimum water flow admitted to the heat exchanger

Q min [2]: minimum water flow admitted to the heat exchanger

Q max: maximum water flow admitted to the heat exchanger

C.a. min: minimum water content admitted in the plant

C.A.S.: Exchanger water content

9.1 ELECTRICAL DATA

TR-W-G05-Z

[SI System]

SIZE	Power supply V/ph/Hz	Maximum values						
		Compressor			Total (1)			
		n	F.L.I. [kW]	F.L.A. [A]	L.R.A. [A]	F.L.I. [kW]	F.L.A. [A]	S.A. [A]
1A00	400/3/50	1	1x102	1x160	n.a.	102,0	160	-
1B00	400/3/50	1	1x148	1x231	n.a.	148,0	231	-
1B1A	400/3/50	2	1x148+1x102	1x231+1x160	n.a.	250,0	391	-
1B2A	400/3/50	3	1x148+2x102	1x231+2x160	n.a.	352,0	551	-
1B3A	400/3/50	4	1x148+3x102	1x231+3x160	n.a.	454,0	711	-
1C00	400/3/50	1	1x120	1x187	n.a.	120,0	187	-
1C1A	400/3/50	2	1x120+1x102	1x187+1x160	n.a.	222,0	347	-
1C1B	400/3/50	2	1x120+1x148	1x187+1x231	n.a.	268,0	418	-
1C3B	400/3/50	4	1x120+3x148	1x187+3x231	n.a.	564,0	880	-
1D00	400/3/50	1	1x138	1x216	n.a.	138,0	216	-
1D1A	400/3/50	2	1x138+1x102	1x216+1x160	n.a.	240,0	376	-
1D1B	400/3/50	2	1x138+1x148	1x216+1x231	n.a.	286,0	447	-
1D1C	400/3/50	2	1x138+1x120	1x216+1x187	n.a.	258,0	403	-
1D2C	400/3/50	3	1x138+2x120	1x216+2x187	n.a.	378,0	590	-
1D3C	400/3/50	4	1x138+3x120	1x216+3x187	n.a.	498,0	777	-
1D4C	400/3/50	5	1x138+4x120	1x216+4x187	n.a.	618,0	964	-
1D5C	400/3/50	6	1x138+5x120	1x216+5x187	n.a.	738,0	1151	-
2A00	400/3/50	2	2x102	2x160	n.a.	204,0	320	-
2B00	400/3/50	2	2x148	2x231	n.a.	296,0	462	-
2B1A	400/3/50	3	2x148+1x102	2x231+1x160	n.a.	398,0	622	-
2B2A	400/3/50	4	2x148+2x102	2x231+2x160	n.a.	500,0	782	-
2B3A	400/3/50	5	2x148+3x102	2x231+3x160	n.a.	602,0	942	-
2C00	400/3/50	2	2x120	2x187	n.a.	240,0	374	-
2C1A	400/3/50	3	2x120+1x102	2x187+1x160	n.a.	342,0	534	-
2C1B	400/3/50	3	2x120+1x148	2x187+1x231	n.a.	388,0	605	-
2D00	400/3/50	2	2x138	2x216	n.a.	276,0	432	-
2D1B	400/3/50	3	2x138+1x148	2x216+1x231	n.a.	424,0	663	-
2D1C	400/3/50	3	2x138+1x120	2x216+1x187	n.a.	396,0	619	-
2D2B	400/3/50	4	2x138+2x148	2x216+2x231	n.a.	572,0	894	-
2D2C	400/3/50	4	2x138+2x120	2x216+2x187	n.a.	516,0	806	-
2D3C	400/3/50	5	2x138+3x120	2x216+3x187	n.a.	636,0	993	-
2D4C	400/3/50	6	2x138+4x120	2x216+4x187	n.a.	756,0	1180	-
3A00	400/3/50	3	3x102	3x160	n.a.	306,0	480	-
3B00	400/3/50	3	3x148	3x231	n.a.	444,0	693	-
3B1A	400/3/50	4	3x148+1x102	3x231+1x160	n.a.	546,0	853	-
3B2A	400/3/50	5	3x148+2x102	3x231+2x160	n.a.	648,0	1013	-
3B3A	400/3/50	6	3x148+3x102	3x231+3x160	n.a.	750,0	1173	-

F.L.I.: Full load power

F.L.A.: Full load current

L.R.A.: Locked rotor amperes for single compressor

S.A.: Inrush current

(1) Safety values to be considered when cabling the unit for power supply and line-protections

Data valid for standard units without any additional option.

Plant (side) cooling exchanger water (in/out) 12,00°C/7,00°C; Source (side) heat exchanger water (in/out) 30,00°C/35,00°C.

Voltage tolerance: 10%

Maximum voltage unbalance: 3%

Given the typical operating conditions of units designed for indoor installation, which can be associated (according to reference document IEC 60721) to the following classes:

- climatic conditions class AA4: air temperature range from 5 up to 42°C (*)
- special climatic conditions negligible
- presence of water class AD2: possibility of water dripping inside the technical room
- biological conditions class 4B1 and 4C2: negligible presence of corrosive and polluting substances
- mechanically active substances class 4S2: locations in areas with sand or dust sources

The required protection level for safe operation, according to reference document IEC 60529, is IP21 BW (protection against access of external devices with diameter larger than 12 mm and water falling vertically).

The unit can be considered IP21 CW protected, thus fulfilling the above operating conditions.

(*) for the unit's operating limits, see "selection limits" section

ELECTRICAL DATA

TR-W-G05-Z

[SI System]

SIZE	Power supply V/ph/Hz	Maximum values						
		Compressor			Total (1)			
		n	F.L.I. [kW]	F.L.A. [A]	L.R.A. [A]	F.L.I. [kW]	F.L.A. [A]	S.A. [A]
3C00	400/3/50	3	3x120	3x187	n.a.	360,0	561	-
3C1A	400/3/50	4	3x120+1x102	3x187+1x160	n.a.	462,0	721	-
3C1B	400/3/50	4	3x120+1x148	3x187+1x231	n.a.	508,0	792	-
3C2B	400/3/50	5	3x120+2x148	3x187+2x231	n.a.	656,0	1023	-
3D00	400/3/50	3	3x138	3x216	n.a.	414,0	648	-
3D1A	400/3/50	4	3x138+1x102	3x216+1x160	n.a.	516,0	808	-
3D1C	400/3/50	4	3x138+1x148	3x216+1x231	n.a.	562,0	879	-
3D2C	400/3/50	5	3x138+3x120	3x216+3x187	n.a.	774,0	1209	-
3D3C	400/3/50	6	3x138+3x120	3x216+3x187	n.a.	774,0	1209	-
4B00	400/3/50	4	4x148	4x231	n.a.	592,0	924	-
4B1A	400/3/50	5	4x148+1x102	4x231+1x160	n.a.	694,0	1084	-
4B2A	400/3/50	6	4x148+2x102	4x231+2x160	n.a.	796,0	1244	-
4C00	400/3/50	4	4x120	4x187	n.a.	480,0	748	-
4C1B	400/3/50	5	4x120+1x148	4x187+1x231	n.a.	628,0	979	-
4D00	400/3/50	4	4x138	4x216	n.a.	552,0	864	-
4D1C	400/3/50	5	4x138+1x120	4x216+1x187	n.a.	672,0	1051	-
4D2C	400/3/50	6	4x138+2x120	4x216+2x187	n.a.	792,0	1238	-
5B00	400/3/50	5	5x148	5x231	n.a.	740,0	1155	-
5B1A	400/3/50	6	5x148+1x102	5x231+1x160	n.a.	842,0	1315	-
5C00	400/3/50	5	5x120	5x187	n.a.	600,0	935	-
5C1B	400/3/50	6	5x120+1x148	5x187+1x231	n.a.	748,0	1166	-
5D00	400/3/50	5	5x138	5x216	n.a.	690,0	1080	-
5D1C	400/3/50	6	5x138+1x120	5x216+1x187	n.a.	810,0	1267	-
6B00	400/3/50	6	6x148	6x231	n.a.	888,0	1386	-
6C00	400/3/50	6	6x120	6x187	n.a.	720,0	1122	-
6D00	400/3/50	6	6x138	6x216	n.a.	828,0	1296	-

F.L.I.: Full load power

F.L.A.: Full load current

L.R.A.: Locked rotor amperes for single compressor

S.A.: Inrush current

(1) Safety values to be considered when cabling the unit for power supply and line-protections

Data valid for standard units without any additional option.

Plant (side) cooling exchanger water (in/out) 12,00°C/7,00°C; Source (side) heat exchanger water (in/out) 30,00°C/35,00°C.

Voltage tolerance: 10%

Maximum voltage unbalance: 3%

Given the typical operating conditions of units designed for indoor installation, which can be associated (according to reference document IEC 60721) to the following classes:

- climatic conditions class AA4: air temperature range from 5 up to 42°C (*)
- special climatic conditions negligible
- presence of water class AD2: possibility of water dripping inside the technical room
- biological conditions class 4B1 and 4C2: negligible presence of corrosive and polluting substances
- mechanically active substances class 4S2: locations in areas with sand or dust sources

The required protection level for safe operation, according to reference document IEC 60529, is IP21 BW (protection against access of external devices with diameter larger than 12 mm and water falling vertically).

The unit can be considered IP21 CW protected, thus fulfilling the above operating conditions.

(*) for the unit's operating limits, see "selection limits" section



10.1 FULL LOAD SOUND LEVEL

TR-W-G05-Z

SOUND POWER LEVEL IN COOLING									
SIZE	Octave band [Hz]								Total sound level dB(A)
	63	125	250	500	1000	2000	4000	8000	
	Sound power level dB								
1A00	82	77	80	78	87	88	84	86	93
1B00	83	82	86	87	90	87	83	83	94
1B1A	84	82	86	86	91	89	85	87	95
1B2A	86	83	86	87	92	91	87	89	97
1B3A	87	83	87	87	93	92	88	90	98
1C00	83	82	86	91	89	88	85	85	95
1C1A	85	82	86	90	90	90	87	88	96
1C1B	85	84	88	91	91	89	86	86	96
1C3B	88	87	91	93	95	92	89	89	99
1D00	84	83	87	92	90	89	86	86	96
1D1A	85	83	87	91	91	91	87	88	97
1D1B	86	85	89	92	92	90	87	87	97
1D1C	85	84	88	93	91	90	87	87	97
1D2C	87	86	90	95	93	92	89	89	99
1D3C	87	86	90	95	93	92	89	89	99
1D4C	88	87	91	96	94	93	90	90	100
1D5C	89	88	92	97	95	94	91	91	101
2A00	84	79	82	80	89	90	86	88	95
2B00	85	84	88	89	92	89	85	85	96
2B1A	86	84	88	89	93	91	87	88	97
2B2A	87	85	89	89	93	92	88	89	98
2B3A	88	86	89	90	94	94	90	91	99
2C00	85	84	88	93	91	90	87	87	97
2C1A	86	84	88	93	92	91	88	89	98
2C1B	86	85	89	93	93	91	88	88	98
2D00	86	85	89	94	92	91	88	88	98
2D1B	87	86	90	94	94	92	89	89	99
2D1C	87	86	90	95	93	92	89	89	99
2D2B	88	87	91	94	94	92	89	89	99
2D2C	88	87	91	96	94	93	90	90	100
2D3C	88	87	91	96	94	93	90	90	100
2D4C	89	88	92	97	95	94	91	91	101
3A00	85	80	83	81	90	91	87	89	96
3B00	86	85	89	90	93	90	86	86	97
3B1A	88	86	90	91	94	92	88	89	98
3B2A	89	87	90	91	95	93	89	90	99
3B3A	89	87	91	91	96	94	90	92	100
3C00	86	85	89	94	92	91	88	88	98
3C1A	88	86	90	95	94	93	90	90	99
3C1B	88	87	91	95	94	93	90	90	99
3C2B	89	88	92	96	95	94	90	90	100
3D00	87	86	90	95	93	92	89	89	99
3D1A	89	87	91	96	94	94	91	91	100
3D1C	88	87	91	96	94	93	90	90	100
3D2C	89	88	92	97	95	94	91	91	101
3D3C	89	88	92	97	95	94	91	91	101
4B00	87	86	90	91	94	91	87	87	98

Working conditions

Plant (side) cooling exchanger water (in/out) 12,00°C/7,00°C; Source (side) heat exchanger water (in/out) 30,00°C/35,00°C.

Sound power on the basis of measurements made in compliance with ISO 9614.

Such certification refers specifically to the sound Power Level in dB(A). This is therefore the only acoustic data to be considered as binding.

Sound power level in cooling, indoors.



FULL LOAD SOUND LEVEL

TR-W-G05-Z

SOUND POWER LEVEL IN COOLING									
SIZE	Octave band [Hz]								Total sound level dB(A)
	63	125	250	500	1000	2000	4000	8000	
	Sound power level dB								
4B1A	88	86	90	91	95	92	88	89	99
4B2A	89	88	92	92	96	94	90	91	100
4C00	87	86	90	95	93	92	89	89	99
4C1B	89	88	92	96	95	94	91	91	100
4D00	88	87	91	96	94	93	90	90	100
4D1C	89	88	92	97	95	94	91	91	101
4D2C	89	88	92	97	95	94	91	91	101
5B00	88	87	91	92	95	92	88	88	99
5B1A	90	88	92	93	96	94	90	90	100
5C00	88	87	91	96	94	93	90	90	100
5C1B	90	89	93	97	96	95	92	92	101
5D00	89	88	92	97	95	94	91	91	101
5D1C	90	89	93	98	96	95	92	92	102
6B00	89	88	92	93	96	93	89	89	100
6C00	89	88	92	97	95	94	91	91	101
6D00	90	89	93	98	96	95	92	92	102

Working conditions

Plant (side) cooling exchanger water (in/out) 12,00°C/7,00°C; Source (side) heat exchanger water (in/out) 30,00°C/35,00°C.

Sound power on the basis of measurements made in compliance with ISO 9614.

Such certification refers specifically to the sound Power Level in dB(A). This is therefore the only acoustic data to be considered as binding.

Sound power level in cooling, indoors.

SOUND PRESSURE LEVEL									
SIZE	Octave band [Hz]								Total sound level dB(A)
	63	125	250	500	1000	2000	4000	8000	
	Sound pressure level dB								
1A00	64	59	62	60	69	70	66	68	75
1B00	65	64	68	69	72	69	65	65	76
1B1A	65	63	67	67	72	70	66	68	76
1B2A	67	64	67	68	73	72	68	70	78
1B3A	67	63	67	67	73	72	68	70	78
1C00	65	64	68	73	71	70	67	67	77
1C1A	66	63	67	71	71	71	68	69	77
1C1B	66	65	69	72	72	70	67	67	77
1C3B	68	67	71	73	75	72	69	69	79
1D00	66	65	69	74	72	71	68	68	78
1D1A	66	64	68	72	72	72	68	69	78
1D1B	67	66	70	73	73	71	68	68	78
1D1C	66	65	69	74	72	71	68	68	78
1D2C	67	66	70	75	73	72	69	69	79
1D3C	67	66	70	75	73	72	69	69	79
1D4C	67	66	70	75	73	72	69	69	79
1D5C	68	67	71	76	74	73	70	70	80
2A00	65	60	63	61	70	71	67	69	76
2B00	66	65	69	70	73	70	66	66	77
2B1A	67	65	69	70	74	72	68	69	78
2B2A	67	65	69	69	73	72	68	69	78

Working conditions

Plant (side) cooling exchanger water (in/out) 12,00°C/7,00°C; Source (side) heat exchanger water (in/out) 30,00°C/35,00°C.

Average sound pressure level at 1m distance, unit in a free field on a reflective surface; non-binding value calculated from the sound power level.

FULL LOAD SOUND LEVEL

TR-W-G05-Z

SOUND PRESSURE LEVEL									
SIZE	Octave band [Hz]								Total sound level dB(A)
	63	125	250	500	1000	2000	4000	8000	
	Sound pressure level dB								
2B3A	67	65	68	69	73	73	69	70	78
2C00	66	65	69	74	72	71	68	68	78
2C1A	66	64	68	73	72	71	68	69	78
2C1B	66	65	69	73	73	71	68	68	78
2D00	67	66	70	75	73	72	69	69	79
2D1B	67	66	70	74	74	72	69	69	79
2D1C	67	66	70	75	73	72	69	69	79
2D2B	68	67	71	74	74	72	69	69	79
2D2C	68	67	71	76	74	73	70	70	80
2D3C	67	66	70	75	73	72	69	69	79
2D4C	68	67	71	76	74	73	70	70	80
3A00	66	61	64	62	71	72	68	70	77
3B00	67	66	70	71	74	71	67	67	78
3B1A	68	66	70	71	74	72	68	69	78
3B2A	68	66	69	70	74	72	68	69	78
3B3A	68	66	70	70	75	73	69	71	79
3C00	66	65	69	74	72	71	68	68	78
3C1A	68	66	70	75	74	73	70	70	79
3C1B	68	67	71	75	74	73	70	70	79
3C2B	68	67	71	75	74	73	69	69	79
3D00	67	66	70	75	73	72	69	69	79
3D1A	69	67	71	76	74	74	71	71	80
3D1C	68	67	71	76	74	73	70	70	80
3D2C	68	67	71	76	74	73	70	70	80
3D3C	68	67	71	76	74	73	70	70	80
4B00	67	66	70	71	74	71	67	67	78
4B1A	67	65	69	70	74	71	67	68	78
4B2A	68	67	71	71	75	73	69	70	79
4C00	67	66	70	75	73	72	69	69	79
4C1B	68	67	71	75	74	73	70	70	79
4D00	68	67	71	76	74	73	70	70	80
4D1C	68	67	71	76	74	73	70	70	80
4D2C	68	67	71	76	74	73	70	70	80
5B00	67	66	70	71	74	71	67	67	78
5B1A	69	67	71	72	75	73	69	69	79
5C00	67	66	70	75	73	72	69	69	79
5C1B	69	68	72	76	75	74	71	71	80
5D00	68	67	71	76	74	73	70	70	80
5D1C	69	68	72	77	75	74	71	71	81
6B00	68	67	71	72	75	72	68	68	79
6C00	68	67	71	76	74	73	70	70	80
6D00	69	68	72	77	75	74	71	71	81

Working conditions

Plant (side) cooling exchanger water (in/out) 12,00°C/7,00°C; Source (side) heat exchanger water (in/out) 30,00°C/35,00°C.

Average sound pressure level at 1m distance, unit in a free field on a reflective surface; non-binding value calculated from the sound power level.

11.1 DIMENSIONAL DRAWINGS

TR-W-G05-Z 1A00 - 6D00

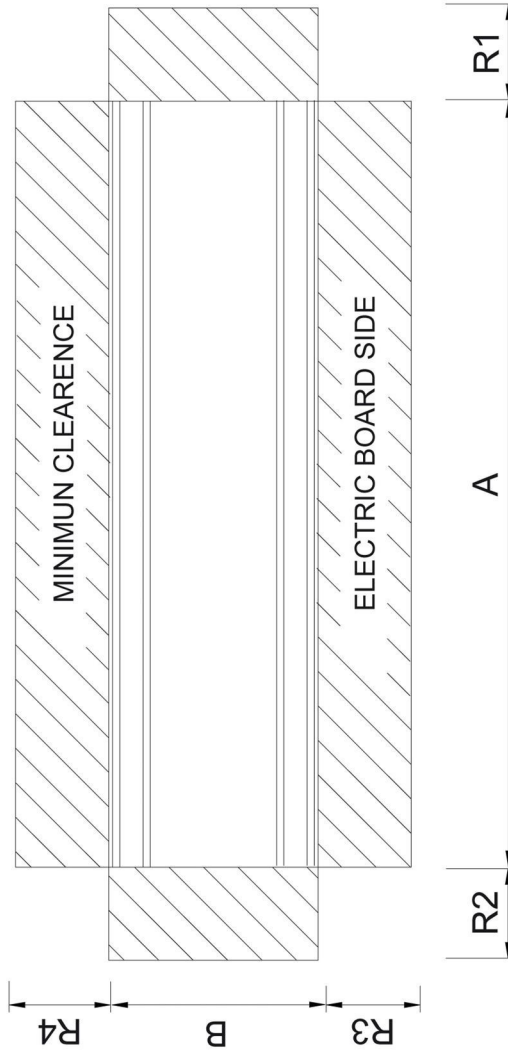
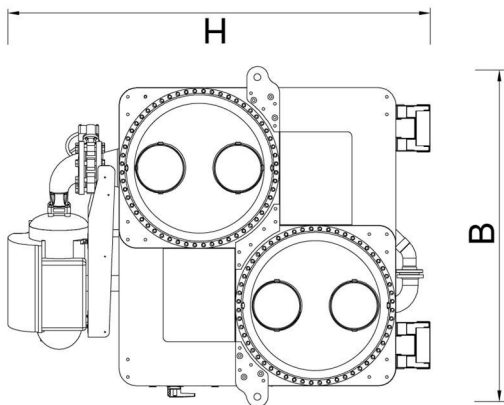
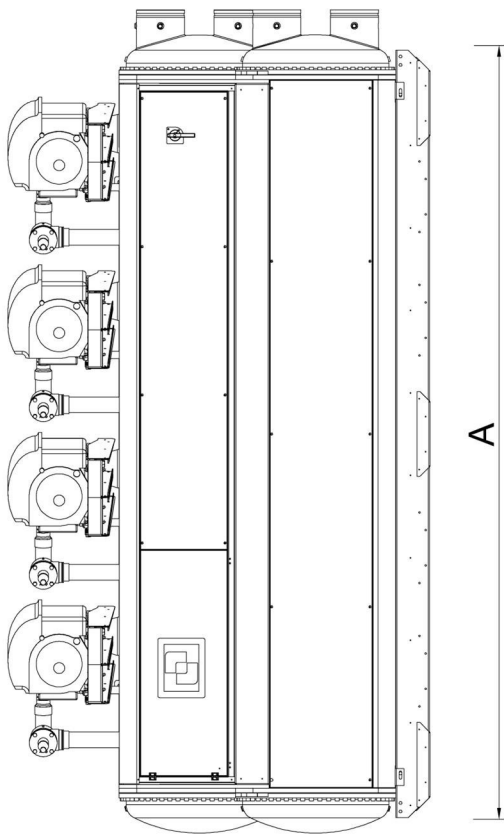
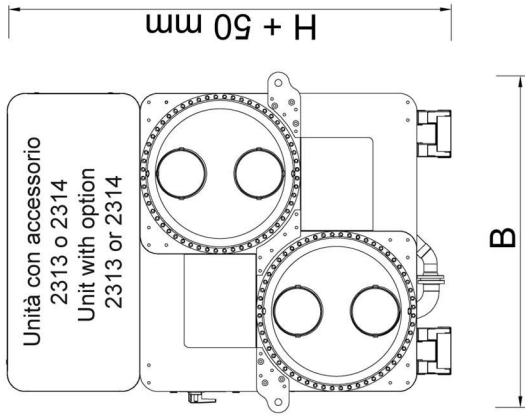

REMARKS: For installation purposes, please refer to the documentation sent after the purchase contract. This technical data should be considered as indicative. Mitsubishi Electric Hydraulics & IT Cooling Systems S.p.A. may modify them at any moment. Data valid for standard units without any additional option.

DIMENSIONAL DRAWINGS

TR-W-G05-Z 1A00 - 6D00

[SI System]

SIZE	DIMENSIONS AND WEIGHTS				CLEARANCE				HEAT EXCHANGER USER SIDE		HEAT EXCHANGER SOURCE SIDE	
	A	B	H WEIGHT		R1	R2	R3	R4	IN/OUT		IN/OUT	
	[mm]	[mm]	[mm]	[kg]	[mm]	[mm]	[mm]	[mm]	TYPE	Ø	TYPE	Ø
TR-W-G05-Z /1A00	2910	1000	1950	2690	1000	2500	1500	1000	VICTAULIC	5"	VICTAULIC	5"
TR-W-G05-Z /1B00	2910	1000	1950	2800	1000	2500	1500	1000	VICTAULIC	5"	VICTAULIC	5"
TR-W-G05-Z /1B1A	3050	1620	2190	5200	1000	2500	1500	1000	VICTAULIC	8"	VICTAULIC	8"
TR-W-G05-Z /1B2A	3710	1710	2260	7590	1000	3000	1500	1000	VICTAULIC	8"	VICTAULIC	8"
TR-W-G05-Z /1B3A	4690	1890	2400	9320	1000	4000	1500	1000	VICTAULIC	8"	VICTAULIC	8"
TR-W-G05-Z /1C00	2910	1000	1950	2880	1000	2500	1500	1000	VICTAULIC	5"	VICTAULIC	5"
TR-W-G05-Z /1C1A	3050	1620	2190	5280	1000	2500	1500	1000	VICTAULIC	8"	VICTAULIC	8"
TR-W-G05-Z /1C1B	3050	1620	2190	5410	1000	2500	1500	1000	VICTAULIC	8"	VICTAULIC	8"
TR-W-G05-Z /1C3B	4720	1890	2400	11010	1000	4000	1500	1000	VICTAULIC	10"	VICTAULIC	10"
TR-W-G05-Z /1D00	2910	1000	1950	2950	1000	2500	1500	1000	VICTAULIC	5"	VICTAULIC	5"
TR-W-G05-Z /1D1A	3050	1620	2190	5350	1000	2500	1500	1000	VICTAULIC	8"	VICTAULIC	8"
TR-W-G05-Z /1D1B	3050	1620	2190	5340	1000	2500	1500	1000	VICTAULIC	8"	VICTAULIC	8"
TR-W-G05-Z /1D1C	3050	1620	2190	5420	1000	2500	1500	1000	VICTAULIC	8"	VICTAULIC	8"
TR-W-G05-Z /1D2C	4690	1660	2260	8810	1000	4000	1500	1000	VICTAULIC	8"	VICTAULIC	8"
TR-W-G05-Z /1D3C	4720	1890	2400	11410	1000	4000	1500	1000	VICTAULIC	10"	VICTAULIC	10"
TR-W-G05-Z /2A00	2910	1560	2190	4070	1000	2500	1500	1000	VICTAULIC	5"	VICTAULIC	5"
TR-W-G05-Z /2B00	3050	1620	2190	5340	1000	2500	1500	1000	VICTAULIC	8"	VICTAULIC	8"
TR-W-G05-Z /2B1A	3710	1710	2260	7750	1000	3000	1500	1000	VICTAULIC	8"	VICTAULIC	8"
TR-W-G05-Z /2B2A	4720	1890	2400	10610	1000	4000	1500	1000	VICTAULIC	10"	VICTAULIC	10"
TR-W-G05-Z /2C00	3050	1620	2190	5330	1000	2500	1500	1000	VICTAULIC	8"	VICTAULIC	8"
TR-W-G05-Z /2C1A	4690	1660	2260	8470	1000	4000	1500	1000	VICTAULIC	8"	VICTAULIC	8"
TR-W-G05-Z /2C1B	4690	1660	2260	8700	1000	4000	1500	1000	VICTAULIC	8"	VICTAULIC	8"
TR-W-G05-Z /2D00	3050	1620	2190	5310	1000	2500	1500	1000	VICTAULIC	8"	VICTAULIC	8"
TR-W-G05-Z /2D1B	4690	1660	2260	8810	1000	4000	1500	1000	VICTAULIC	8"	VICTAULIC	8"
TR-W-G05-Z /2D1C	4690	1660	2260	8880	1000	4000	1500	1000	VICTAULIC	8"	VICTAULIC	8"
TR-W-G05-Z /2D2B	4720	1890	2400	11250	1000	4000	1500	1000	VICTAULIC	10"	VICTAULIC	10"
TR-W-G05-Z /2D2C	4720	1890	2400	11450	1000	4000	1500	1000	VICTAULIC	10"	VICTAULIC	10"
TR-W-G05-Z /3A00	3710	1710	2260	7440	1000	3000	1500	1000	VICTAULIC	8"	VICTAULIC	8"
TR-W-G05-Z /3B00	3710	1710	2260	7370	1000	3000	1500	1000	VICTAULIC	8"	VICTAULIC	8"
TR-W-G05-Z /3B1A	4720	1890	2400	10740	1000	4000	1500	1000	VICTAULIC	10"	VICTAULIC	10"
TR-W-G05-Z /3C00	4690	1660	2260	8700	1000	4000	1500	1000	VICTAULIC	8"	VICTAULIC	8"
TR-W-G05-Z /3C1A	4720	1890	2400	11010	1000	4000	1500	1000	VICTAULIC	10"	VICTAULIC	10"
TR-W-G05-Z /3C1B	4720	1890	2400	11210	1000	4000	1500	1000	VICTAULIC	10"	VICTAULIC	10"
TR-W-G05-Z /3D00	4690	1660	2260	9010	1000	4000	1500	1000	VICTAULIC	8"	VICTAULIC	8"
TR-W-G05-Z /3D1A	4720	1890	2400	11250	1000	4000	1500	1000	VICTAULIC	10"	VICTAULIC	10"
TR-W-G05-Z /3D1C	4720	1890	2400	11580	1000	4000	1500	1000	VICTAULIC	10"	VICTAULIC	10"
TR-W-G05-Z /4B00	4720	1890	2400	10920	1000	4000	1500	1000	VICTAULIC	10"	VICTAULIC	10"
TR-W-G05-Z /4C00	4720	1890	2400	11250	1000	4000	1500	1000	VICTAULIC	10"	VICTAULIC	10"
TR-W-G05-Z /4D00	4720	1890	2400	11580	1000	4000	1500	1000	VICTAULIC	10"	VICTAULIC	10"

DIMENSIONAL DRAWINGS

TR-W-G05-Z 1A00 - 6D00

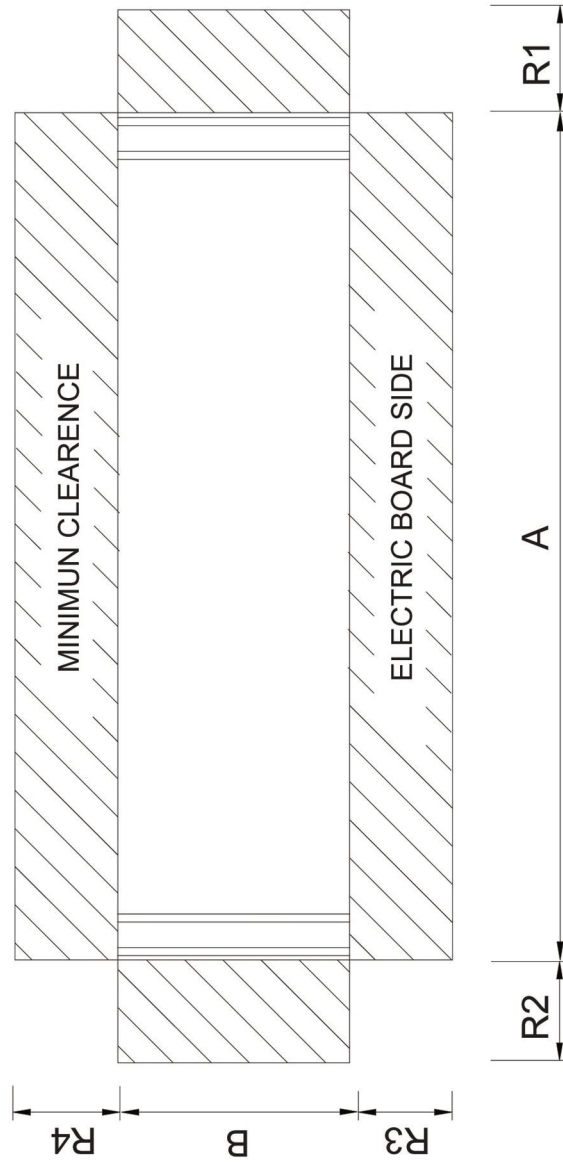
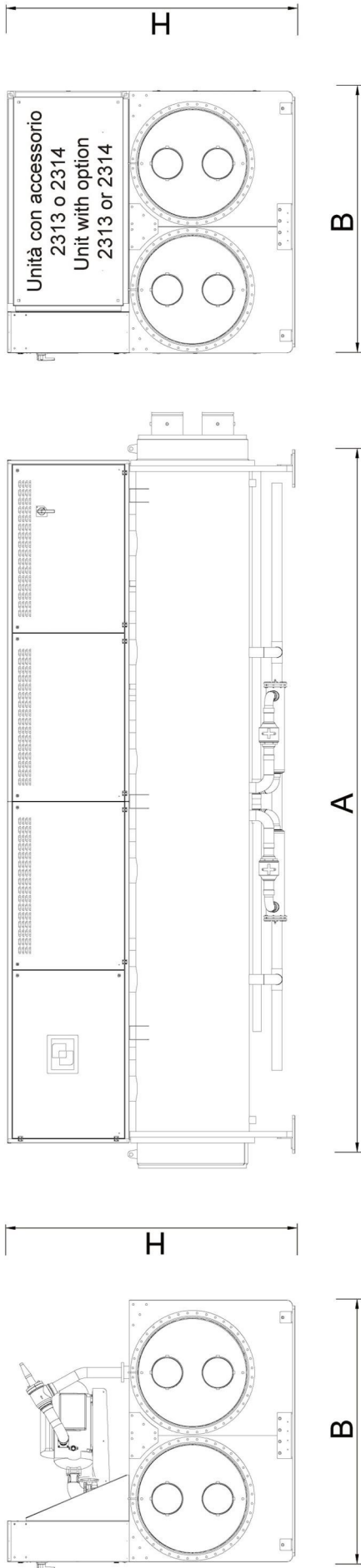

REMARKS: For installation purposes, please refer to the documentation sent after the purchase contract. This technical data should be considered as indicative. Mitsubishi Electric Hydraulics & IT Cooling Systems S.p.A. may modify them at any moment. Data valid for standard units without any additional option.

DIMENSIONAL DRAWINGS

TR-W-G05-Z 1A00 - 6D00

[SI System]

SIZE	DIMENSIONS AND WEIGHTS				CLEARANCE				HEAT EXCHANGER USER SIDE		HEAT EXCHANGER SOURCE SIDE	
	A	B	H WEIGHT		R1	R2	R3	R4	IN/OUT		IN/OUT	
	[mm]	[mm]	[mm]	[kg]	[mm]	[mm]	[mm]	[mm]	TYPE	Ø	TYPE	Ø
TR-W-G05-Z /1D4C	5700	2350	2400	15330	1000	4800	1500	1000	VICTAULIC	12"	VICTAULIC	12"
TR-W-G05-Z /1D5C	6610	2400	2450	20580	1000	5800	1500	1000	VICTAULIC	12"	VICTAULIC	12"
TR-W-G05-Z /2B3A	5700	2350	2400	13850	1000	4800	1500	1000	VICTAULIC	12"	VICTAULIC	12"
TR-W-G05-Z /2D3C	5700	2350	2400	15420	1000	4800	1500	1000	VICTAULIC	12"	VICTAULIC	12"
TR-W-G05-Z /2D4C	6610	2400	2450	20750	1000	5800	1500	1000	VICTAULIC	12"	VICTAULIC	12"
TR-W-G05-Z /3B2A	5700	2350	2400	14050	1000	4800	1500	1000	VICTAULIC	12"	VICTAULIC	12"
TR-W-G05-Z /3B3A	6610	2400	2450	18670	1000	5800	1500	1000	VICTAULIC	12"	VICTAULIC	12"
TR-W-G05-Z /3C2B	5700	2350	2400	14910	1000	4800	1500	1000	VICTAULIC	12"	VICTAULIC	12"
TR-W-G05-Z /3D2C	5700	2350	2400	15500	1000	4800	1500	1000	VICTAULIC	12"	VICTAULIC	12"
TR-W-G05-Z /3D3C	6610	2400	2450	21010	1000	5800	1500	1000	VICTAULIC	12"	VICTAULIC	12"
TR-W-G05-Z /4B1A	5700	2350	2400	14300	1000	4800	1500	1000	VICTAULIC	12"	VICTAULIC	12"
TR-W-G05-Z /4B2A	6610	2400	2450	18880	1000	5800	1500	1000	VICTAULIC	12"	VICTAULIC	12"
TR-W-G05-Z /4C1B	5700	2350	2400	15000	1000	4800	1500	1000	VICTAULIC	12"	VICTAULIC	12"
TR-W-G05-Z /4D1C	5700	2350	2400	15730	1000	4800	1500	1000	VICTAULIC	12"	VICTAULIC	12"
TR-W-G05-Z /4D2C	6610	2400	2450	21180	1000	5800	1500	1000	VICTAULIC	12"	VICTAULIC	12"
TR-W-G05-Z /5B00	5700	2350	2400	14550	1000	4800	1500	1000	VICTAULIC	12"	VICTAULIC	12"
TR-W-G05-Z /5B1A	6610	2400	2450	19150	1000	5800	1500	1000	VICTAULIC	12"	VICTAULIC	12"
TR-W-G05-Z /5C00	5700	2350	2400	15180	1000	4800	1500	1000	VICTAULIC	12"	VICTAULIC	12"
TR-W-G05-Z /5C1B	6610	2400	2450	20240	1000	5800	1500	1000	VICTAULIC	12"	VICTAULIC	12"
TR-W-G05-Z /5D00	5700	2350	2400	15890	1000	4800	1500	1000	VICTAULIC	12"	VICTAULIC	12"
TR-W-G05-Z /5D1C	6610	2400	2450	21350	1000	5800	1500	1000	VICTAULIC	12"	VICTAULIC	12"
TR-W-G05-Z /6B00	6610	2400	2450	19400	1000	5800	1500	1000	VICTAULIC	12"	VICTAULIC	12"
TR-W-G05-Z /6C00	6610	2400	2450	20410	1000	5800	1500	1000	VICTAULIC	12"	VICTAULIC	12"
TR-W-G05-Z /6D00	6610	2400	2450	21560	1000	5800	1500	1000	VICTAULIC	12"	VICTAULIC	12"

DIMENSIONAL DRAWINGS

LEGEND OF PIPE CONNECTIONS



TYPE = H
Grooved coupling with weld end counter-pipe user side

NOMINAL PIPE SIZE	PIPE OUTSIDE DIAMETER
ø inches	ø mm
¾	26,7
1	33,7
1 ¼	42,4
1 ½	48,3
2	60,3
2 ½	76,1
3	88,9
3 ½	101,6

NOMINAL PIPE SIZE	PIPE OUTSIDE DIAMETER
ø inches	ø mm
4	114,3
4 ½	127,0
5	139,7
6	168,3
8	219,1
10	273,0
12	323,9
14	355,6

UNI ISO 228/13

Pipe threads where pressure-tight joints are not made on the threads - Designation, dimensions and tolerances

Used terminology:

G: Pipe threads where pressure-tight joints are not made on the threads

A: Close tolerance class for external pipe threads where pressure-tight joints are not made on the threads

B: Wider tolerance class for external pipe threads where pressure-tight joints are not made on the threads

Internal threads: G letter followed by thread mark (only tolerance class)

External threads: G letter followed by thread mark and by A letter for A class external threads or by B letter for B class external threads.

UNI EN 10226-1

Pipe threads where pressure-tight joints are made on the threads - Designation, dimensions and tolerances

Used terminology:

Rp: Internal cylindrical threads where pressure-tight joints are made on the threads

Rc: Internal conical threads where pressure-tight joints are made on the threads

R: External conical threads where pressure-tight joints are made on the threads

Internal cylindrical threads: R letter followed by p letter

Internal conical threads: R letter followed by c letter

External conical threads: R letter

DESIGNATION	DESCRIPTION
UNI EN 10226-1 - Rp 1 1/2	Internal cylindrical threads where pressure-tight joints are made on the threads, defined by standard UNI ISO 7/1 Conventional ø 1 1/2"
UNI EN 10226-1 - Rp 2 1/2	Internal cylindrical threads where pressure-tight joints are made on the threads, defined by standard UNI ISO 7/1 Conventional ø 2 1/2"
UNI EN 10226-1 - Rp 3	Internal cylindrical threads where pressure-tight joints are made on the threads, defined by standard UNI ISO 7/1 Conventional ø 3"
UNI EN 10226-1 - R 3	External conical threads where pressure-tight joints are made on the threads, defined by standard UNI ISO 7/1 Conventional ø 3"
UNI ISO 228/1 - G 4 B	Internal cylindrical threads where pressure-tight joints are not made on the threads, defined by standard UNI ISO 228/1 Tolerance class B for external thread Conventional ø 4"
DN 80 PN 16	Flange Nominal Diameter: 80 mm Nominal Pressure: 16 bar

NOTE:

Conventional diameter value [in inches] identifies short thread designation, based upon the relative standard.

All relative values are defined by standards.

As example, here below some values:

	UNI EN 10226-1	UNI ISO 228/1
Conventional ø	1"	1"
Pitch	2.309 mm	2.309 mm
External ø	33.249 mm	33.249 mm
Core ø	30.291 mm	30.291 mm
Thread height	1.479 mm	1.479 mm

A.1 VARIABLE FLOW HYDRAULIC GROUP (optional)

A.2 VPF systems for plants designed with a single variable flow hydraulic circuit

The energy consumption associated with fluid circulation weighs heavily on the total operating costs of a large installation, especially when the units work at part load, and even more, when they are in stand-by. Under these conditions, although the power absorbed by the compressors and fans (if present) is reduced, the power consumed for water circulation remains high. The system power consumption can be reduced using pumps with continuous flow control by inverter. Energy savings are considerable and immediately evident, to the extent that a Δx reduction of the flow of water to be delivered to the system, amounts to a proportional reduction of ($\Delta \dot{x}$) in the power absorbed. In the most advanced systems these ones become the pumps for the entire hydraulic circuit, and this eliminates the need to detach the primary circuit, dedicated to the circulation of the water on the units side, from the secondary one, dedicated to water circulation throughout the entire system. In traditional systems it was the only choice possible and imposed mostly by the need for the chiller to work with constant water flow through the evaporator. Now designers can work without worrying about this limit, as Climaveneta units are designed to work with the maximum efficiency even with variable flow through the evaporator, managing the resources independently, in order to keep the outlet water temperature constantly at the set-point entered by the user. This simplifies the design and realization of variable flow systems and offers advantages in terms of both reductions in consumption and hydraulic circuit sizing. The integration of pumps + inverters built-in the unit permits significant savings in space, circuit components, and system start-up times.

The VPF (Variable Primary Flow system) is the Climaveneta solution that allows to have the variable water flow on the user side (evaporator) in the plants with primary circuit only.

The VPF kit includes the following devices:

- control device (called DP3 in the herebelow scheme), mounted on the electrical panel, and pressure differential transducer (with 4-20 mA signal), mounted on the heat exchanger user side
- control device (called PL3 in the herebelow scheme), positioned inside the electrical panel
- 0-10V signals for the communication between the pumps and the controller of the unit.

To these ones it's mandatory to add (not supplied by Climaveneta):

- pressure transducer on plant side, with the dedicated signal 4-20 mA for the communication with the PL3 device (this transducer must be installed on the longest (worst) leg of the installation)
- 2 way by-pass valve, with a dedicated 0-10V signal for the communication with the PL3 device
- inverter pumps.

When the plant includes more units connected together with a management system (Manager 3000), it's mandatory to order also the option 3030 "VPF control from Manager 3000", in order to have the installation of the PL3 device inside the Manager itself and not in the electrical panel of each unit.

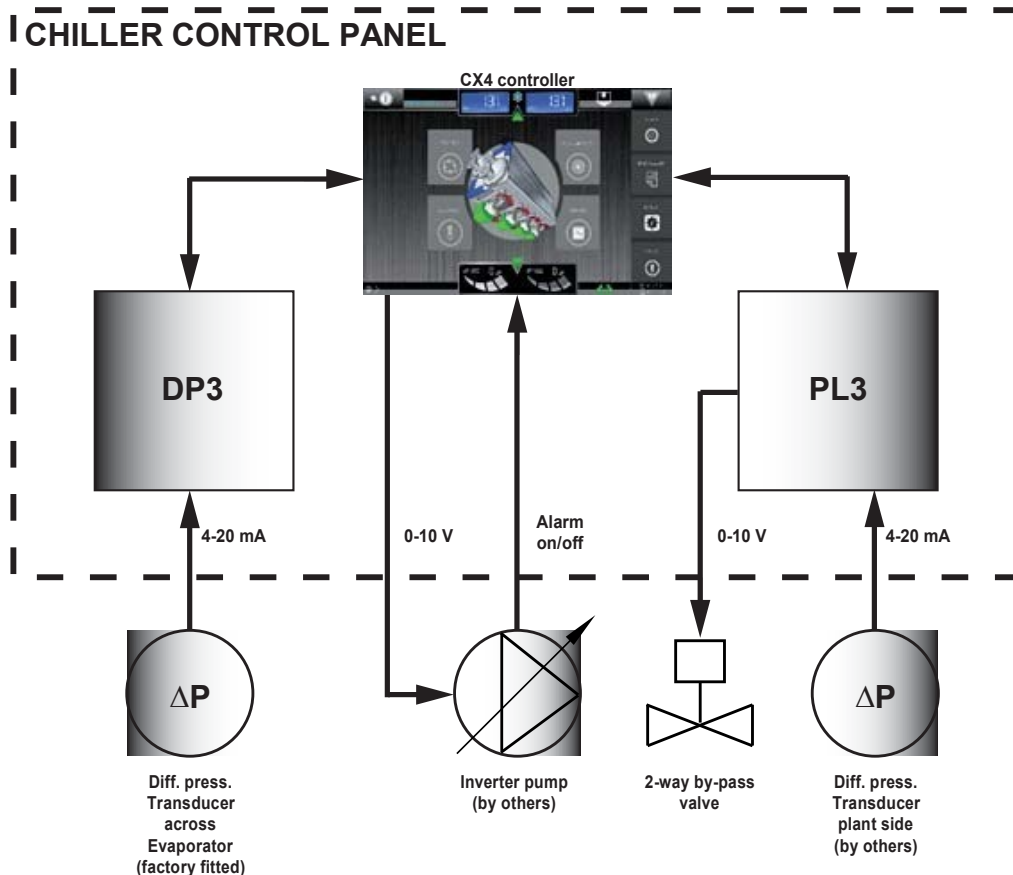

How it works

The VPF option measures the differential pressure across the installation in order to keep it between a minimum and a maximum value programmed in the PL3 device. As long as the measured value remains inside this range, the output signal to the pumps remains the same. On the other side when the measured value is bigger than the maximum programmed, the signal to the pumps is decreased, and in case the measured value results smaller than the minimum programmed, the signal to the pumps is increased. In any case the change of signal is performed through step by step adjustments and monitoring constantly the effects in order to avoid rough changes and guaranteeing the return of the measured value inside the programmed range as much quickly as possible.

In case the differential pressure requires a water flow smaller than the minimum necessary for the heat exchanger, the DP3 device communicates with the controller in the meantime that the PL3 send to the by-pass valve the signal to open gradually in order to protect the chiller.

When the plant includes more units, the working logic remains the same. The PL3 device, installed in the Manager, collects the information from the pressure transducer mounted in the plant (in common for all the units) and communicates with the by-pass valve (this one too in common for all the units), while the differential transducer mounted on each evaporator, the related DP3 device and the management of the pumps+inverters are duty of the controller of each unit.

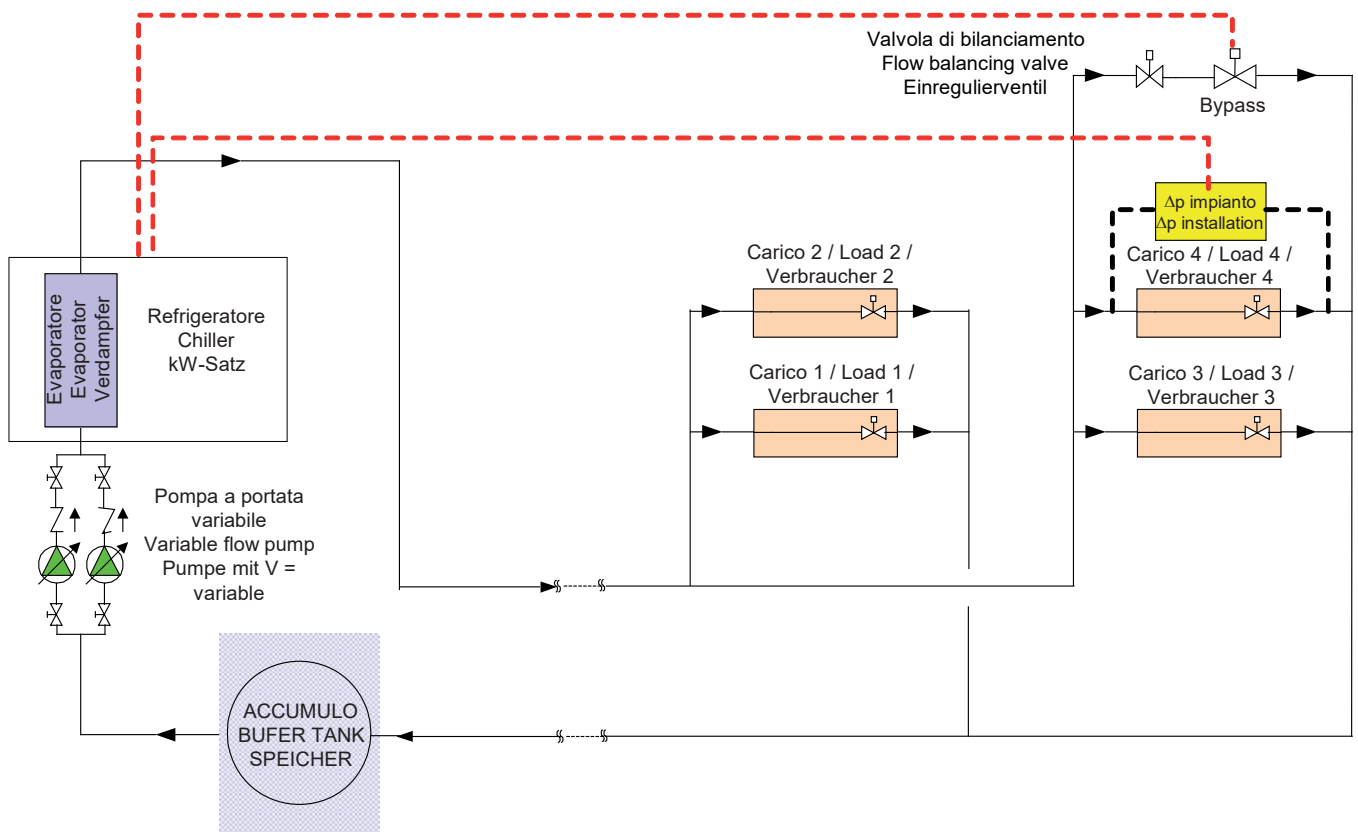

A.3 VPF.D systems for plants designed with both primary circuit and secondary one with variable flow

Also in those cases when it's not possible to design a single circuit with variable flow or when it's necessary to maintain decoupled the primary circuit (dedicated to the chillers) and the secondary one (dedicated to the plant users), it's possible to have the management of the pumps and inverters directly from the unit.

The energy savings are lower than the solution with a unique VPF system, but still important especially when the units are in stand-by, as in this case it's possible to reduce down to 50% the water flow.

These systems can be easily adopted in retrofit application, where the chiller is supposed to be replaced but the plant isn't.

The Climaveneta solution guarantees also the water flow balancing between primary and secondary circuit, in order to avoid the flow inversion in the decoupling pipe.

The VPF.D system (Variable Primary Flow with Decoupler) is the option that allows to have variable water flow on the user side exchanger (evaporator) in plants with both primary and secondary circuits and additional pumps on the user side.

The VPF.D option includes:

- control device (PL3 in the herebelow scheme), mounted in the electrical panel
- 2 temperature probes, provided by Climaveneta but installed by the client in the plant, one for the delivery line and one for the by-pass line
- 0-10V signals for the communication between the pumps and the controller of the unit.

Pumps and related inverters are to be provided and installed by others.

When the plant includes more units connected together with a management system (Manager 3000), it's mandatory to order also the option 3030 "VPF control from Manager 3000", in order to have the installation of the PL3 device inside the Manager itself and not in the electrical panel of each unit.

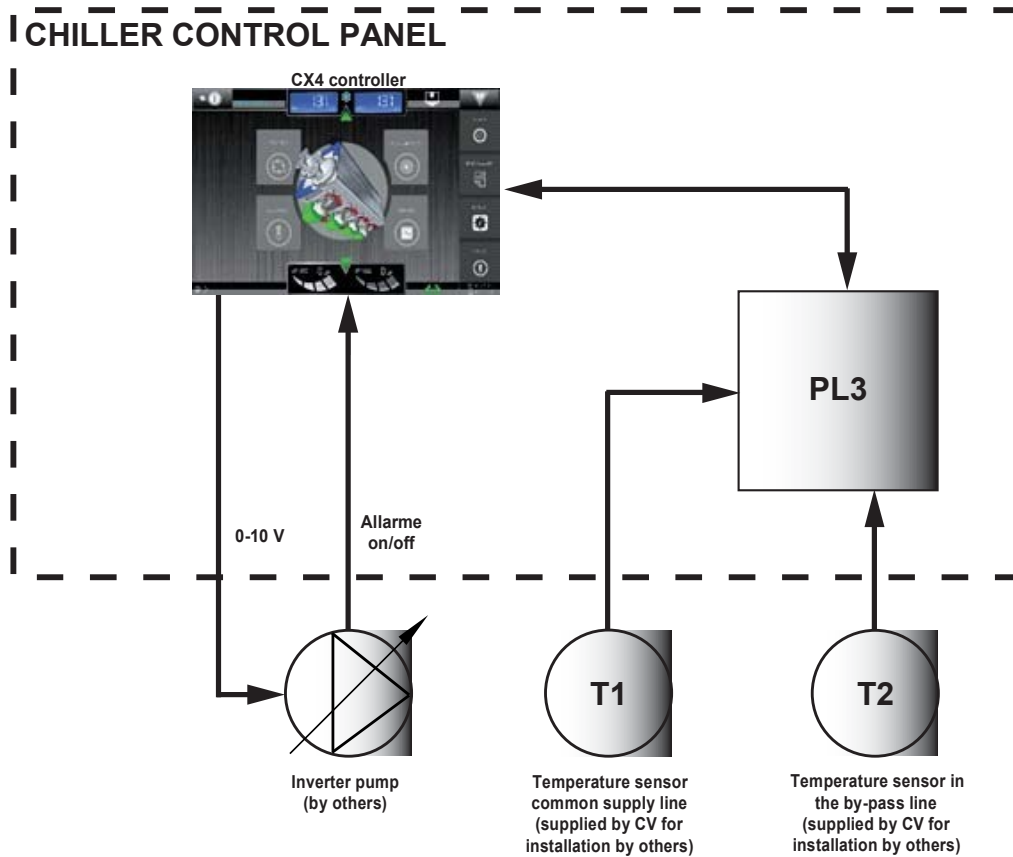

How it works

The VPF. D measures, through the two probes installed, the temperatures T1 and T2 (on the delivery and by-pass lines), keeping T2=T1 as control target.

As long as T1=T2, the water flow in the primary circuit is equal or higher than in the secondary one. When T2>T1, the water flow in the primary circuit becomes lower than the flow in the secondary circuit, leading to recirculation of warm water coming back from the installation and mixing with the cold supply water.

In order to rebalance this situation the speed of the pumps is being increased gradually in order to let the temperature T1 be again equal to T2.

The target of the VPF.D is then to keep constant the ΔT in the primary circuit. The secondary circuit remains completely independent and so has to be managed and controlled by the customer side.

The minimum water flow through the user side exchanger is guaranteed by a fixed setting for the minimum speed of the pumps (inside the service menu of the unit controller).

When the plant includes more units, the working logic remains the same. The PL3 device, installed in the Manager, collect the information about temperatures T1 and T2, while the controller of each unit takes care of the speed of the pumps, according to the signal sent from the Manager. The Manager itself takes care also that the pumps of each chiller work at the same speed and that, when an additional unit is switched on, the speed of the already running pumps is automatically aligned.

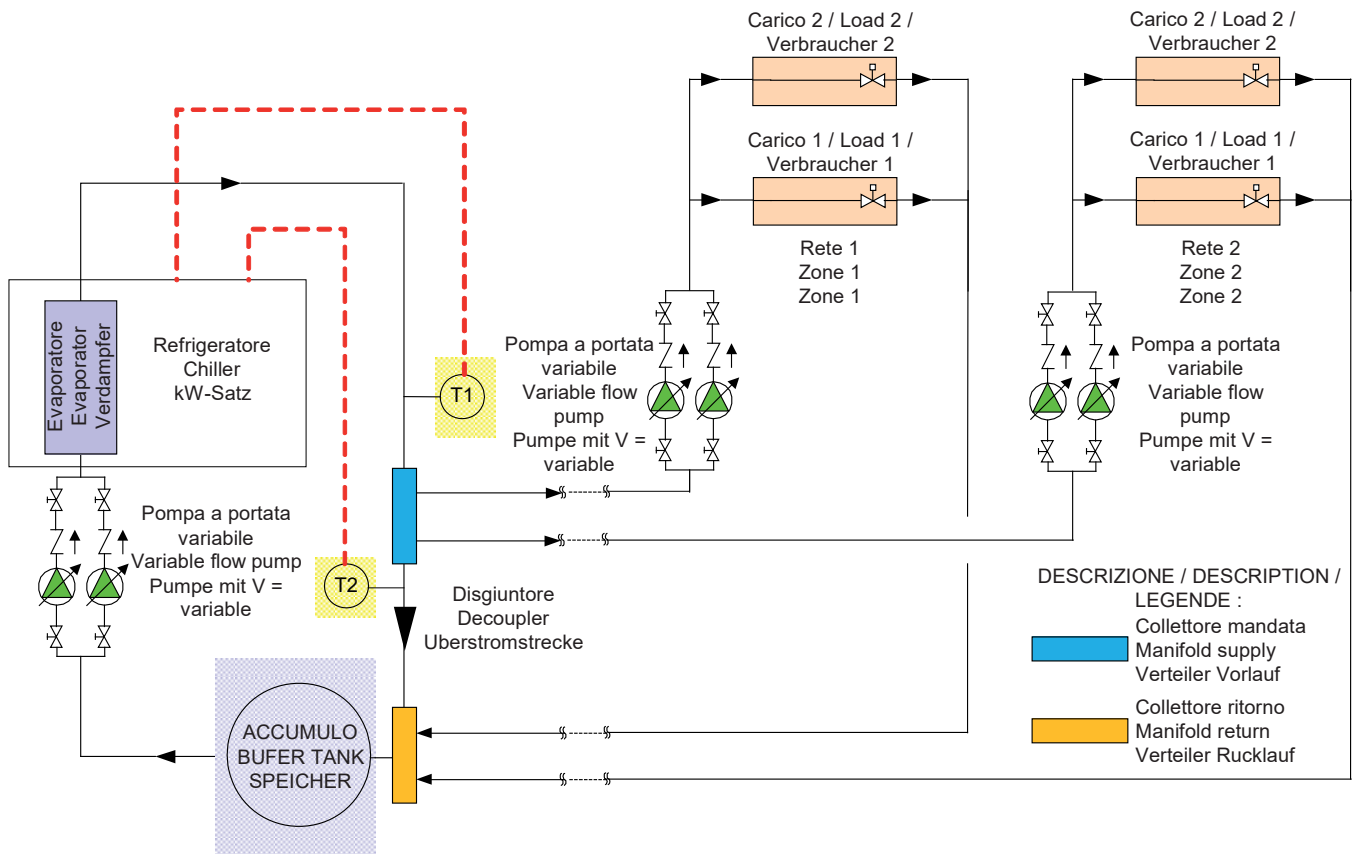

A.4 For VPF system: indications for the bypass pipe sizing

Differential pressure transducer on the farrest pipe of the plant and bypass valve are at customer charge.
Climaveneta provides only some indications for the plants design, as a function of the minimum waterfl ow on the primary heat exchanger.

Minimum waterfl ow to technical bulletin		Kvs	Recommended valve	E Valve	Valve motor	E ByPass
[m ³ /h]	[GPM]					
From 19 to 30	From 69,7 to 110	40	VVG41.50	DN50	SKB60	DN50 (2")
up to 37	up to 136	49	VVF31.65	DN65	SKB60	DN65 (2"½)
up to 60	up to 220	78	VVF31.80	DN80	SKB60	DN80 (3")
up to 95	up to 348	124	VVF31.90	DN100	SKC60	DN100 (4")
up to 150	up to 550	200	VVF31.91	DN125	SKC60	DN125 (5")
up to 230	up to 843	300	VVF31.92	DN150	SKC60	DN150 (6")

2-way valve and minimum recommended bypass pipe diameter as a function of the minimum waterfl ow.

A.5 For VPF.D system: indications for the decoupling pipe sizing

Climaveneta provides in the table below some indications for the plants design, as a function of the nominal waterfl ow on the primary heat exchanger.

NOTE: temperature probes are separately supplied

Minimum waterfl ow to technical bulletin		E Decoupling pipe
[m ³ /h]	[GPM]	
From 25 to 40	From 91,7 to 147	2"½
up to 60	up to 220	3"
up to 100	up to 367	4"
up to 150	up to 550	5"
up to 225	up to 825	6"
up to 375	up to 1375	8"

Minimum decoupling pipe diameter as a function of the minimum waterfl ow

B.1 COMPRESSOR REPHASING AND ELECTROMAGNETIC COMPATIBILITY

B.2 The harmonic distortion due to power frequency conversion

The increasing need for chillers to work with high efficiency at part loads has led to the introduction of the frequency converter (commonly called inverter) in order to drive the compressor.

The frequency converter varies the compressor's rotation speed through the regeneration of the power voltage, keeping its amplitude and frequency under control, through a conversion of the electrical power in two steps: first with a AC→DC rectifier and then with a inverter DC→AC inverter.

The use of the frequency converter determines an AC current characterized by a non-sine periodic wave form with given frequency f. This wave can be broken out into a sine wave called pure wave and a certain number of waves with greater frequencies (multiples of f), called harmonic waves and numbered with rising odd numbers (3°, 5°, 7°, ...).

B.3 Power Factor, Displacement Power Factor and Total Harmonic Distortion

The harmonic waves do not contribute to the absorption of active power from the power source, but their presence causes:

- The presence of voltage harmonics that worsen the quality of the grid power voltage thus leading to possible malfunctions of the loads connected to this power grid.
- The worsening of the unit power factor PF, resulting in higher charges for the client from the electricity distribution company.

The Power Factor PF of a system is equal to the ratio between the active power and the apparent power and it is formulated in the following way:

$$PF = \frac{1}{\sqrt{1 + THD_i^2}} DPF$$

DPF (Displacement Power Factor) is equal to the cosφ of the pure current wave.

THD (Total Harmonic Distorsion) is the rate which describes the amount of the harmonic distortion. In particular THDi refers to the current wave and THDv to the voltage wave.

It is therefore clear that, whenever harmonics are present, the Power Factor PF is different from the Displacement Power Factor, and that the heavier the harmonics are, the greater the difference is.

In general, frequency converters are characterized by an intrinsic constant DPF (Displacement Power Factor) value between 0.97 and 0.99, while the Power Factor PF varies according to the load conditions, usually becoming worse when load partialization increases.

The following table displays the values of Power Factor PF and current Total Harmonic Distortion for the units of the family TX-W:

Size	MAXIMUM		Size	MAXIMUM		Size	MAXIMUM		Size	MAXIMUM		Size	MAXIMUM	
	P.F.	THDi [%]		P.F.	THDi [%]		P.F.	THDi [%]		P.F.	THDi [%]		P.F.	THDi [%]
1A00	0,92	28,8	2D00	0,92	36,4	2B2A	0,92	30,9	2B3A	0,92	30,6	4B2A	0,92	31,4
1B00	0,92	32,1	3A00	0,92	28,8	3B1A	0,92	31,6	3B2A	0,92	31,2	5B1A	0,92	31,8
1C00	0,91	37,8	1B2A	0,92	30,3	4B00	0,92	32,1	4B1A	0,92	31,7	6B00	0,92	32,1
1D00	0,92	36,4	2B1A	0,92	31,4	1C3B	0,92	33,4	5B00	0,92	32,1	5C1B	0,91	36,7
2A00	0,92	28,8	3B00	0,92	32,1	3C1A	0,91	36,1	3C2B	0,91	35,3	6C00	0,91	37,8
1B1A	0,92	30,9	2C1A	0,91	35,5	3C1B	0,91	36,2	4C1B	0,91	36,5	1D5C	0,91	37,5
1C1A	0,91	34,1	1B3A	0,92	30	2D2B	0,92	34,3	5C00	0,91	37,8	2D4C	0,91	37,3
2B00	0,92	32,1	2C1B	0,91	35,7	4C00	0,91	37,8	1D4C	0,91	37,5	3D3C	0,91	37,1
1D1A	0,92	33,6	3C00	0,91	37,8	3D1A	0,92	35,2	2D3C	0,91	37,2	4D2C	0,91	36,8
1C1B	0,91	34,8	2D1B	0,92	35	1D3C	0,91	37,4	3D2C	0,91	36,9	5D1C	0,91	36,6
1D1B	0,92	34,3	1D2C	0,91	37,3	2D2C	0,91	37,1	4D1C	0,91	36,7	6D00	0,92	36,4
2C00	0,91	37,8	2D1C	0,91	36,8	3D1C	0,91	36,7	5D00	0,92	36,4			
1D1C	0,91	37,1	3D00	0,92	36,4	4D00	0,92	36,4	3B3A	0,92	30,9			

Values calculated at Maximum water conditions (considering worst possible load conditions)

The objective and unquestionable THDi measurement of a device can only be taken when the device is working in a power grid with some specific characteristics as described in the reference standards (e.g.: CEI EN 61000-3-12). Where the measurement of the THDi value is performed without a standardized power voltage, the resulting values are influenced by the THDv value of the power grid.

To control THDi values, all TX-W units have inductive reactances on the compressors' line. Their presence, however, entails a decay of Displacement Power Factor DPF value, which can still be reset to 0.95 with the accessory "3302- Power factor correction to 0.95".

For installations where the control of the THDi values is crucial, active harmonic modular filters are available: they're a device that analyzes the line current harmonics drawn by the loads and generates a compensation current at an opposite phase angle thereby neutralizing the harmonic currents, to obtain a THDi less than 5%.

The harmonic current is reduced in all the working conditions of the unit.

Active harmonic modular filters are subject to RFQ (feasibility and quote request) and are supplied not mounted on the unit



for a greener tomorrow

Eco Changes is the Mitsubishi Electric Group's environmental statement, and expresses the Group's stance on environmental management. Through a wide range of businesses, we are helping contribute to the realization of a sustainable society.



MITSUBISHI ELECTRIC HYDRONICS & IT COOLING SYSTEMS S.p.A.

Head Office: Via Roma 5 - 27010 Valle Salimbene (PV) - Italy

Tel +39 (0) 382 433 811 - Fax +39 (0) 382 587 148

www.melcohit.com